

Troubleshooting and Repair of Consumer Electronics Equipment

Contents:

- [Chapter 1\) About the Author & Copyright](#)
- [Chapter 2\) Introduction](#)
- [2.1\) Getting into troubleshooting](#)
- [2.2\) Nick's comments on 'how to learn repair'](#)
- [2.3\) If you decide that you don't want to bother repairing something](#)
- [2.4\) Smoking around electronic equipment](#)
- [Chapter 3\) Basic troubleshooting](#)
- [3.1\) Some of my rules of troubleshooting](#)
- [3.2\) Some quick tips or rules of thumb](#)
- [3.3\) On-line tech-tips databases](#)
- [3.4\) Getting inside consumer electronic equipment](#)
- [Chapter 4\) Tools, Test Equipment, and Other Stuff](#)
- [4.1\) Hand tools](#)
- [4.2\) Basic test equipment](#)
- [4.3\) So you can't afford a \\$20,000 transient event recorder?](#)
- [4.4\) Transformers - isolation and variable](#)
- [4.5\) Isolation transformers](#)
- [4.6\) Typical homemade isolation transformer](#)
- [4.7\) Isolation transformers from dead microwave ovens](#)
- [4.8\) How safe is a homemade isolation transformer?](#)
- [4.9\) Variable autotransformers](#)
- [4.10\) Variable isolation transformers](#)
- [4.11\) Variac/isolation transformer with current limiting](#)
- [4.12\) What about the scope ground?](#)
- [4.13\) Basic Ancillary Equipment](#)
- [4.14\) Incredibly handy widgets\(tm\)](#)
- [4.15\) Miscellaneous](#)
- [4.16\) Making a bench power supply from a PC power supply](#)
- [Chapter 5\) Soldering and Desoldering Equipment and Techniques](#)
- [5.1\) Solder is not glue](#)
- [5.2\) Soldering equipment](#)
- [5.3\) Soldering techniques](#)
- [5.4\) Desoldering techniques](#)
- [5.5\) Nick's comments on successful desoldering techniques](#)
- [5.6\) Soldering pins in plastic connectors](#)
- [Chapter 6\) Supplies and Parts](#)
- [6.1\) Lubricants, cleaning agents, and other liquidy or slimy stuff](#)
- [6.2\) Adhesives](#)
- [6.3\) Electronic sealers and potting compounds](#)
- [6.4\) Electronic parts](#)
- [6.5\) Mechanical parts](#)
- [Chapter 7\) Sources of Information and General Comments](#)
- [7.1\) References](#)
- [7.2\) Manufacturer's service literature](#)
- [7.3\) Identifying OEM manufacturer - FCC numbers](#)
- [7.4\) Sams' Photofacts](#)
- [7.5\) Inside cover of the equipment](#)
- [7.6\) Additional sources for service information and manuals](#)
- [7.7\) Canadian schematics source](#)
- [7.8\) Reverse engineered schematics](#)

- [7.9\) Mark's approach to finding information](#)
- [7.10\) Parts information and cross references](#)
- [7.11\) Transistor designations](#)
- [7.12\) Surface mount parts](#)
- [7.13\) House numbers](#)
- [7.14\) Generic parts \(mostly semiconductors\)](#)
- [7.15\) HP-to-industry standard semiconductor cross-reference](#)
- [7.16\) Internet sources of information](#)
- [7.17\) Are there schematics of consumer electronic equipment on the Web?](#)
- [7.18\) Taking the unit to a repair shop](#)
- [7.19\) Searching for information from the USENET newsgroups](#)
- [7.20\) Posting to sci.electronics.repair](#)
- [Chapter 8\) Parts Sources](#)
- [8.1\) Where to go for parts](#)
- [8.2\) Web parts information and ordering](#)
- [8.3\) Mail order parts sources](#)
- [8.4\) And, don't forget Radio Shack](#)
- [Chapter 9\) Perfecting your skills](#)
- [9.1\) Where to find equipment in need of repair or abuse](#)
- [9.2\) Paul's comments on the 'well equipped garage or flea market sale-er'](#)
- [9.3\) And, how Paul equipped his home lab](#)
- [9.4\) Too bad about the good old days](#)
- [9.5\) Harrie's notes on repair](#)
- [9.6\) Roger's comments on troubleshooting](#)

[Document Version: 1.35] [Last Updated: 05/25/1998]

Chapter 1) About the Author & Copyright

Troubleshooting and Repair of Consumer Electronics Equipment

Author: Samuel M. Goldwasser

Corrections/suggestions: [Feedback Form](#) | [Email](#)

Copyright (c) 1994, 1995, 1996, 1997, 1998
All Rights Reserved

Reproduction of this document in whole or in part is permitted if both of the following conditions are satisfied:

1. This notice is included in its entirety at the beginning.
2. There is no charge except to cover the costs of copying.

Note: this document includes and supersedes the documents: "Repair Briefs, an Introduction" and "[Sources of Information and General Comments](#)".

Chapter 2) Introduction

2.1) Getting into troubleshooting

This document attempts to provide an entry to the world of consumer electronics troubleshooting and repair. It also covers test equipment selection, tools and supplies, parts, home made troubleshooting aide - Incredibly Handy Widgets(tm) - and safety.

Mostly, you will learn by doing. However, you do need to prepare.

There are many schools dedicated to electronics repair. Some of these are quite good. Many are not. This document, however, is written from the perspective of the motivated do-it-yourselfer, hobbieist, and tinkerer.

The Repair FAQs usually list suggested references for each area. Your local public or university library will probably have some of these or other repair oriented electronics books.

Above all read and understand the document: "[Safety Guidelines for High Voltage and/or Line 1](#) fabulous large screen won't be of much use to you if you are dead.

Collect broken electronics and appliances from your friends, relatives, the dump, garage sales and flea markets, etc. Start on those that have been written off - you will screw up at first. We all did. As times passes, your batting average will improve. It may not happen overnight but it will happen if you apply yourself. There will be many relatively easy successes but the 'tough dogs' may make up for these triumphs. Don't let them get to you - not everything can be repaired. Sometimes, the basic design is flawed or someone before you messed up royally. Troubleshooting is like being a detective but at least the device is generally not out to deceive you.

Experience will be your most useful companion.

If you go into the profession, you will obtain or have access to a variety of tech tips databases. These are an excellent investment where the saying: 'time-is-money' rules. However, to learn, you need to develop a general troubleshooting approach - a logical, methodical, method of narrowing down the problem. A tech tip database might suggest: 'Replace C536' for a particular symptom. This is good advice for a specific problem on one model. However, what you really want to understand is why C536 was the cause and how to pinpoint the culprit in general even if you don't have a service manual or schematic and your tech tip database doesn't have an entry for your sick TV or VCR.

While schematics are nice, you won't always have them or be able to justify the purchase for a one-of repair. Therefore, in many cases, some reverse engineering will be necessary. The time will be well spent since even if you don't see another instance of the same model in your entire lifetime, you will have learned something in the process that can be applied to other equipment problems.

As always, when you get stuck, the sci.electronics.repair newsgroup will still exist!

Happy repairing!

2.2) Nick's comments on 'how to learn repair'

(From: Nicholas Bodley (nbodley@tiac.net)).

Here's how I see it:

By all means, do what you can to understand basic principles first. Your success will be much more likely when you understand how a device works. If you can, read Electronics Now and Popular Electronics, as well as Nuts and Volts (<http://www.nutsvolts.com>). Also have a look at the Radio Amateur's Handbook.

These periodicals are not carefully edited, unfortunately, and now and then things get into print that are simply wrong or misleading, but they are still useful; I learned quite a bit from their predecessors (Radio Craft and Radio News!).

I can't speak firsthand, but it might be a very good idea to become (eventually) a Certified Electronic Technician. Look up the I.S.C.E.T.

Hearsay and folklore sometimes indicate that you should replace a given part when certain symptoms occur, and in the case of frequent failures of such parts, this information might even be true. But that's no way to become a competent technician.

My personal take is that you have to know when to 'let go' of an hypothesis about what the cause of the trouble is. A tech. who persists beyond a certain point in his belief that such-and-such is causing the problem is stuck and spinning his wheels. (I'm sexist; I think women are far less likely to get stuck this way! I think it's a male trait. :)

Troubleshooting is a special field of knowledge and has its own special outlook on things. The device did work, after all.

Production testing and troubleshooting is different; you are likely to be the first person to apply power to a device, and the device has never worked before. If the assemblers aren't giving you excellent quality, you can have some remarkably-bizarre symptoms with a poorly laid-out board from solder shorts, for instance.

A variable toroidal autotransformer (universally known by what used to be a General Radio trade name, Variac) is priceless for troubleshooting circuits that handle any amount of power and which are powered by the AC line. (Not all devices function at all at, say, half of rated AC input; I work on a poorly-designed amplifier that draws many amps at something like 70 volts with no signal and no load. Unfortunately, Variacs and their equivalents are horribly expensive, at least from some sources! If you get a used one, see that the contact area of the winding is undamaged; you might need to remove a knob and some covers to see it. If the knob is stiff, try some contact/control cleaner/lube; it did wonders for mine!

Learn how to operate a 'scope, and learn why you see what you do. I suspect that some techs are not too well-informed about what goes on inside a 'scope; learn from reliable sources!

Learn to use a digital multimeter, and an analog one as well; the latter is easily damaged if you don't know what you're doing, but it's a great trend indicator.

Learn to use a function generator, and use the triangle output as well! Nothing like a triangle to show a wee bit of clipping or limiting in an amplifier...

Learn how to solder! Solder is not an adhesive; it's a metallurgical bond, according to some sources I trust. It just about has to be with gold, at least! If you *really* want to learn soldering, NASA has developed training courses that will make you a disgustingly good solderer.

2.3) If you decide that you don't want to bother repairing something

So, you already have 10 VCRs and really don't want to even pop the case on yet another one.

Don't just toss it in the trash. See if a local charity like the Salvation Army or Goodwill accepts broken appliances and electronics. They may have someone on staff who can perform at least simple repairs and then resell the item. Not only will this reduce clutter in the land fill, you may benefit on your taxes (and in the good deeds department). However, it really isn't proper to do this if you have already worked on the item and given up or reduced it to a pile of slag!

2.4) Smoking around electronic equipment

Note: This is my token editorial but the effects on both people and equipment is very real.

If you still doubt the harmful effects of the chemical compounds in tobacco smoke on your health and that of others around you, whatever I say below probably won't matter and you may want to skip it since it may upset you. However, perhaps, you worry more about your fancy, costly, finely tuned electronic entertainment and computer equipment. In that case, read on.

The several hundred chemical compounds found in tobacco smoke have the following effects on electronic equipment. What isn't trapped in your lungs or in the lungs of those around you:

- * coats the precision optics of CD and DVD players, CDROM and DVDROM drives, and other optical disc/k equipment AND the media they use.
- * coats the read/write heads of floppy disk drives, Zip drives, tape drives, AND the media they use.
- * coats the tape path of VCRs and audio decks including the audio, video, and control heads AND the cassettes and tape inside.
- * coats mechanical parts and promotes the loss of lubrication in all equipment.
- * may contribute to deterioration of plastic and rubber parts.
- * coats the screens of TVs and monitors, display windows of VCRs and other devices, and the outside and inside of everything eventually resulting in ugly brown discoloration and a horrible stench.

This list of effects goes on and on.

The resulting film WILL eventually cause problems and is very difficult to remove. Damage done due to chemical action may require the replacement of costly parts. Increased maintenance will be needed or the equipment may simply fail before its time and not be worth fixing. Contamination will often find its way into critical places that are not accessible and to media which is irreplaceable.

When someone tries to get me to look at something that has been in a smoker's residence (I know because it will reek of stale tobacco smoke essence), my first inclination is to put it in a sealed bag to go out with the garbage. (I have been known to drop portable TVs directly into the nearest trash can under these circumstances.) If this isn't an option, my next objective is to get it evaluated and repaired or refused as quickly as possible. However, my concentration may not be at its peak for such equipment! It is a good thing that I don't need to do this for a living - I would have to refuse service to

a good portion of the world's population :-).

So, now you have a few more reasons to give up the stupid, disgusting, filthy, obnoxious, inconsiderate of others, costly, dangerous, killer habit!

Sorry, end of editorial :-).

Chapter 3) Basic troubleshooting

3.1) Some of my rules of troubleshooting

1. Safety first - know the hazards associated with the equipment you are troubleshooting. Take all safety precautions. Expect the unexpected. Take your time.
2. Always think 'what if'. This applies both to the analytic procedures as well as to precautions with respect to probing the equipment. When probing, insulate all but the last 1/8" of the probe tip to prevent costly shorts. (If I had a nickel for every time I have been screwed not following this advice...)
3. Learn from your mistakes. We all make mistakes - some of them can be quite costly. A simple problem can turn into an expensive one due to a slip of the probe or being over eager to try something before thinking it through. While stating that your experience in these endeavors is measured by the number of scars you have may be stretching the point, expect to screwup - we all can point to that disaster due to inexperience or carelessness. Just make it a point not to make the same mistake again.
4. Don't start with the electronic test equipment, start with some analytical thinking. Many problems associated with consumer electronic equipment do not require a schematic (though one may be useful). The majority of problems with VCRs, CD players, tape decks, and answering machines, are mechanical and can be dealt with using nothing more than a good set of precision hand tools; some alcohol, degreaser, contact cleaner, light oil and grease; and your powers of observation (and a little experience). Your built in senses and that stuff between your ears represents the most important test equipment you have.
5. If you get stuck, sleep on it. Sometimes, just letting the problem bounce around in your head will lead to a different more successful approach or solution. Don't work when you are really tired - it is both dangerous and mostly non-productive (or possibly destructive).
6. Many problems have simple solutions. Don't immediately assume that your problem is some combination of esoteric complex convoluted failures. For a TV, it may just be a bad connection or failed diode. For a VCR, it may just be a bad belt or idler tire - or an experiment in rock placement by your 3-year old. For a CD player, a dirty lens or need for lubrication. Try to remember that the problems with the most catastrophic impact on operation - a dead TV or a VCR that eats tapes - usually have the simplest solutions. The kind of problems we would like to avoid at all costs are the ones that are intermittent or difficult to reproduce: subtle color noise, the occasional interference, or the dreaded horizontal output transistor blowing out every 3 months syndrome.
7. Whenever possible, try to substitute a working unit. With modular systems like component stereos and computers, narrowing down a

problem to a single unit should be the first priority. This is usually safe to do in such cases and will quickly identify which unit needs work. This same principle applies at the electronic or mechanical parts level. Note that there is the possibility of damaging the known good part by putting it into a non-working device or vice versa. This risk is most likely with the power circuitry in amplifiers, TVs and monitors, power supplies, etc. With appropriate precautions (like the series light bulb) the risk can be minimized.

8. Don't blindly trust your instruments. If you get readings that don't make sense, you may be using your equipment in a way which is confusing it. DMMs are not good at checking semiconductors in-circuit or the power transistor you are testing may have a built in damper diode and/or base resistor. Your scope may be picking up interference which is swamping the low level signal you are searching for (TVs and Monitors, or low level circuits in VCRs and CD players). Your frequency counter may be double triggering due to noise or imperfect signal shape.
9. Realize that coincidences do happen but are relatively rare. Usually, there is a common cause. For example, if a TV has no vertical deflection and no picture, it is much more likely that a common power supply output has failed than for parts in both the deflection and video subsystems to be bad. In other words, first look for a common root cause rather than trying to locate bad parts in separate circuits.

Exceptions include lightning, power surge, dropped, water, or previous repair person damaged equipment. However, multiple electrolytic capacitors in older equipment may be degrading resulting in failures of unrelated circuits. Determine if all the problems you are troubleshooting have just appeared - see below. It is very common to be given a device to repair which has now died totally but prior to this had some behavior which you consider marginal but that was not noticed by the owner.

10. Confirm the problem before diving into the repair. It is amazing how many complaints turn out to be impossible to reproduce or are simple cockpit error. It also makes sense to identify exactly what is and is not working so that you will know whether some fault that just appeared was actually a preexisting problem or was caused by your poking. Try to get as much information as possible about the problem from the owner. If you are the owner, try to reconstruct the exact sequence of events that led to the failure. For example, did the TV just not work when turned on or were there some preliminary symptoms like a jittery or squished picture prior to total failure? Did the problem come and go before finally staying bad for good?
11. Get used to the idea of working without a schematic. While service info for TVs is nearly always available in the form of Sams' Photofacts, this is hardly ever true of other types of equipment. Sams VCRfacts exist for less than 10 percent of VCR models and only the older ones include anything beyond (obvious) mechanical information. While a service manual may be available from the manufacturer of your equipment or another Sams-like source, it may not include the information you really need. Furthermore, there may be no way to justify the cost for a one time repair. With a basic understanding of how the equipment works, many problems can be dealt with without a schematic. Not every one but quite a few.
12. Whenever working on precision equipment, make copious notes and diagrams. You will be eternally grateful when the time comes to reassemble the unit. Most connectors are keyed against incorrect insertion or interchange of cables, but not always. Apparently identical screws may be of differing lengths or have slightly different thread types. Little parts may fit in more than one place or orientation. Etc. Etc.
13. Pill bottles, film canisters, and plastic ice cube trays come in handy for sorting and storing screws and other small parts after disassembly. This is particularly true if you have repairs on multiple pieces of equipment under way simultaneously.

14. Select a work area which is wide open, well lighted, and where dropped parts can be located - not on a deep pile shag rug. The best location will also be relatively dust free and allow you to suspend your troubleshooting to eat or sleep or think without having to pile everything into a cardboard box for storage.
15. Understand the risk of ESD - Electro-Static Discharge. Some components (like ICs) in solid state electronic devices are vulnerable to ESD. There is no need to go overboard but taking reasonable precautions such as getting into the habit of touching a ****safe**** ground point first.

WARNING: even with an isolation transformer, a live chassis should ****not**** be considered a safe ground point. This applies mostly to TVs, computer and video monitors, some AC operated strobe lights, and other line connected devices. You shouldn't be touching components with the device powered and plugged in (at least, not until you really know what you are doing!). Once unplugged, sheet metal shields or other ground points should be safe and effective.

3.2) Some quick tips or rules of thumb

- * Problems that are erratic or intermittent - that come and go suddenly - are almost always due to bad connections - cold solder joints or internal or external connectors that need to be cleaned and reseated. It is amazing what a large percentage of common problems fall into the category.
- * Problems that change gradually - usually they decrease or disappear - as the equipment warms up are often due to dried up electrolytic capacitors.
- * Problems that result in a totally dead unit or affect multiple functions are generally power supply related. These are usually easy to fix.
- * Catastrophic failures often result in burnt, scorched, cracked, exploded, or melted components, or similar catastrophic consequences. Use your senses of sight and smell for the preliminary search for such evidence.
- * Listen for signs of arcing or corona - snapping or sizzling sounds. A component on the brink of failing due to overheating may provide similar audible clues.
- * Most VCR problems are mechanical in nature. Worn or deteriorated rubber parts, gummed up lubrication, or abuse (bad tapes or toy storage.).
- * Many CD player problems are mechanical - dirty lens, worn or oily drawer belts, dirt/gummed up grease on sled tracks/gears, bad/partially shorted spindle or sled motor. Power problems with portables seem to be common as well. No matter what the symptoms, always make it a habit to clean the lens first - many peculiar failure modes are simply due to a dirty lens. Actual laser failure is relatively uncommon despite what the typical service shop may claim. CD players are also remarkably robust. Optical alignment should never be needed under normal conditions of operation.
- * TV and monitor problems are very often power supply or deflection related. These tend to have obvious causes - blown posistor, rectifier diodes, filter capacitor, HOT, or chopper. Flyback with shorted windings or shorts between windings or in the voltage multiplier (if used) or screen/focus divider network are also common. Where the HOT or chopper is involved, operation should be observed after the repair as components in the vicinity may cause the new parts to fail. HOTs should generally not run hot. If they do, check for weak drive, excess B+, etc.
- * Microwave oven problems are almost always power related. Faulty components

in the microwave generator - magnetron, HV diode, HV capacitor, HV transformer - are relatively easy to identify. Sometimes, components on the primary side can cause baffling symptoms like the misaligned interlock switches that blow fuses or the weak triac that causes the oven to blow the main fuse only when the cycle *ends*. Control problems may be due to a spill in the touchpad or failure due to a power surge.

- * Ink-jet printers are extremely reliable electrically. Look for simple problems such as caked ink in the 'service station' area, misaligned print-head contacts, or a nearly empty cartridge when erratic printing problems develop.
- * Laser printers tend to develop problems in the fuser, scanner, or power control modules. These are often simple like a burned out lamp, bad motor, or bad connections.
- * Turntables or record changer problems are very likely to be due to gummed up grease.
- * Problems with audio tape decks like VCRs are mostly mechanical. Similar solutions apply. Where one channel is out, suspect a broken wire at the tape head before a bad chip.
- * Telephone line connected equipment like modems and phones are susceptible to phone like surges. Where a device seems to respond to user commands but does not dial or pickup, suspect a blown part near the phone line connector.
- * Sam's Magic Spit(tm). This approach - using a moistened finger to probe LOW VOLTAGE CIRCUITS has come to the rescue many times. Touching various parts of a circuit from the solder side of the board in an attempt to evoke some sort of response can work wonders. Once an suspect area has been identified, use a metal probe or nail to narrow it down to a specific pin.

The reason this works is that the reduced resistance of your moist skin and your body capacitance will change the signal shape and/or introduce some slight signal of its own.

- Logic circuits - marginal timing or signal levels will result in a dramatic change in behavior with a slight 'body' load. It has been possible to locate a race condition or glitchy signal on a 305 pin PGA chip using this approach in less time than it would have taken to roll the logic analyzer over to the system under test. Signals which have proper levels and timing are generally remarkably immune to this sort of torture.
- Analog circuits - behavior can again be altered. In the case of audio amps, probing with a finger is just as effective as the use of a signal injector - which is what you are doing - and the equipment is always handy. By evoking hum, buzz, clicks, and pops, locating the live or dead parts of a circuit is rapid and effective.
- Unknown circuits - where no schematics are available, it may be possible to get the device to do something or locate an area that is sensitive to probing. The function of a section of circuitry can often be identified by observing the effects of touching the components in that area.

For example, I was able to quickly identify the trigger transistor of in a wireless door bell by using my finger to locate the point that caused the chimes to sound. This quickly confirmed that the problem was in the RF front end or decoder and not the audio circuitry.

- Bad bypass capacitors - touching the power/signal side of a good bypass cap should result in little or no effect. However, a cap with high ESR and/or reduced uF will not be doing its job bypassing the pickup from your finger to ground - there will be a dramatic effect in audio or video systems.

Don't get carried away - too much moisture may have unforeseen consequences.

Depending on the condition of your skin, a tingle may be felt even on low voltage circuits under the right conditions. However, this is pretty safe for most battery operated devices, TTL/CMOS logic, audio equipment (not high power amps), CD players, VCRs (not switching power supply), etc.

WARNING: Make sure you do this only with LOW VOLTAGE circuitry. You can easily fry yourself if you attempt to troubleshoot your TV, computer monitor, photoflash, or microwave oven in this manner!

3.3) On-line tech-tips databases

A number of organizations have compiled databases covering thousands of common problems with VCRs, TVs, computer monitors, and other electronics equipment. Most charge for their information but a few, accessible via the Internet, are either free or have a very minimal monthly or per-case fee. In other cases, a limited but still useful subset of the for-fee database is freely available.

A tech-tips database is a collection of problems and solutions accumulated by the organization providing the information or other sources based on actual repair experiences and case histories. Since the identical failures often occur at some point in a large percentage of a given model or product line, checking out a tech-tips database may quickly identify your problem and solution.

In that case, you can greatly simplify your troubleshooting or at least confirm a diagnosis before ordering parts. My only reservation with respect to tech-tips databases in general - this has nothing to do with any one in particular - is that symptoms can sometimes be deceiving and a solution that works in one instance may not apply to your specific problem. Therefore, an understanding of the hows and whys of the equipment along with some good old fashioned testing is highly desirable to minimize the risk of replacing parts that turn out not to be bad.

The other disadvantage - at least from one point of view - is that you do not learn much by just following a procedure developed by others. There is no explanation of how the original diagnosis was determined or what may have caused the failure in the first place. Nor is there likely to be any list of other components that may have been affected by overstress and may fail in the future. Replacing Q701 and C725 may get your equipment going again but this will not help you to repair a different model in the future.

One alternative to tech-tips databases is to search at <http://www.dejanews.com> for postings with keywords matching your model and problem and the newsgroup sci.electronics.repair. See the section: "[Searching for information from the USENET newsgrou](#)

Having said that, here are some tech-tips sites for computer monitors, TVs, and VCRs:

- * <http://www.anatekcorp.com/techforum.htm> (Free).
- * <http://www.repairworld.com/> (\$8/month).
- * <http://elmswood.guernsey.net/> (Free, very limited).
- * <http://ramiga.rnet.cgl.com/electronics/info.html> (free large text files).

A web site that is in the process of accumulating a variety of technical and service information for consumer electronics is [TEKINFO](#). There are sub-pages for all common categories of equipment such as CD players, monitors, TVs, VCRs, etc., with model specific tech-tips as well as general information (including copies of the "Notes on the Troubleshooting and Repair of....." documents in some cases. Specific information is currently somewhat limited but this could become an excellent FREE resource in the future. I would recommend checking this site out from time-to-time and contributing where possible.

This one has quite a bit of info for TVs (at present):

* http://home.inreach.com/ba501/Tech_Tip_Page.htm

The following is just for monitors. Some portions are free but others require a \$5 charge. However, this may include a personal reply from a technician experienced with your monitor so it could be well worth it.

* <http://www.netis.com/members/bcollins/monitor.htm>

Some free monitor repair tips:

* <http://www.kmrtech.com/>

Tech-tips of the month and 'ask a wizard' options:

* <http://members.tripod.com/~ADCC/> (Home page)

* <http://members.tripod.com/~ADCC/tips.htm> (Tech-tips of the month)

The following is specifically for microwave ovens. In addition to a large database of specific repairs, there is a great deal of useful information and links to other sites.

* <http://www.gallawa.com/microtech/>

These types of sites seem to come and go so it is worth checking them out from time-to-time even if you don't have a pressing need. If possible, download and archive any useful information for use on a rainy day in the future.

3.4) Getting inside consumer electronic equipment

Note: the documents on specific equipment has additional 'getting inside' info as well.

Yes, you will void the warranty, but you knew this already.

Hint: The crowbar and 12 pound hammer are *laset* resorts! Really :-).

Manufacturers seem to take great pride in being very mysterious as to how to open their equipment. Not always, but this is too common to just be a coincidence. Opening the equipment non-destructively may be the most difficult and challenging part of many repairs!

A variety of techniques are used to secure the covers on consumer electronic equipment:

1. Screws. Yes, many still use this somewhat antiquated technique. Sometimes, there are even embossed arrows on the case indicating which screws need to be removed to get at the guts. In addition to obvious screw holes, there may be some that are only accessible when a battery or cassette compartment is opened or a trim panel is popped off.

These will often be of the Philips variety. (Strictly speaking, many of these are not actual Philips head screws but a slight variation. Nonetheless, a Philips screwdriver of suitable size will work on them.) A precision jeweler's screwdriver set including miniature Philips head drivers is a must for repair of miniature portable devices.

Sometimes, you will find Torx or a variety of security type fasteners. Suitable driver bits are available. Sometimes, you can improvise using regular tools. In the case of security Torx, the center post can usually be broken off with a pair of needlenose pliers allowing a normal Torx driver to be used. In a pinch, a suitable size hex wrench can

substitute for a Torx driver. Places like MCM Electronics carry a variety of security bits.

2. Hidden screws. These will require prying up a plug or peeling off a decorative decal. It will be obvious that you were tinkering - it is virtually impossible to put a decal back in an undetectable way. Sometimes the rubber feet can be pryed out revealing screw holes. For a stick-on label, rubbing your finger over it may permit you to locate a hidden screw hole. Just puncture the label to access the screw as this may be less messy than attempting to peel it off.
3. Snaps. Look around the seam between the two halves. You may (if you are lucky) see points at which gently (or forcibly) pressing with a screwdriver will unlock the covers. Sometimes, just going around the seam with a butter knife will pop the cover at one location which will then reveal the locations of the other snaps.
4. Glue. Or more likely, the plastic is fused together. This is particularly common with AC adapters (wall warts). In this case, I usually carefully go around the seam with a hacksaw blade taking extreme care not to go through and damage internal components. Reassemble with plastic electrical tape.
5. It isn't designed for repair. Don't laugh. I feel we will see more and more of this in our disposable society. Some devices are totally potted in Epoxy and are throwaways. With others, the only way to open them non-destructively is from the inside.

Don't force anything unless you are sure there is no alternative - most of the time, once you determine the method of fastening, covers will come apart easily. If they get hung up, there may be an undetected screw or snap still in place.

The most annoying (to be polite) situation is when after removing the 18 screws holding the case together (losing 3 of them entirely and mangling the heads on 2 others), removing three subassemblies, and two other circuit boards, you find that the adjustment you wanted was accessible through a hole in the case just by partially peeling back a rubber hand grip!

When reassembling the equipment make sure to route cables and other wiring such that they will not get pinched or snagged and possibly broken or have their insulation nicked or pierced and that they will not get caught in moving parts. Replace any cable ties that were cut or removed during disassembly and add additional ones of your own if needed. Some electrical tape may sometimes come in handy to provide insulation insurance as well.

For those hard-to-open LCD panels:

(From: Onat Ahmet (onat@turbine.kuee.kyoto-u.ac.jp))

The LCD display housings are usually secured by plastic catches built into the case. They still may have a couple of screws that are positioned in the most innovative places! Obvious places are sides of the display, and under stickers (rub your finger over a sticker and see if you can feel the hole for a screw). Also, try to look around the hinge connecting the LCD to the main housing. Look with the LCD closed, and also open; rotating open the housing might hide some screws from view. Expect it to be awkward! BTW, do not forget small hatches, that do not look like one!

After that, it is patience, and knowing the right place to twist the case to pop it open. Try not to use screwdrivers; they leave unsightly marks along the seam.

Also, if it is your own unit, and you break a few of the catches along the way, do not worry; you can put the housing back together with a few spots of adhesive.

Chapter 4) Tools, Test Equipment, and Other Stuff

4.1) Hand tools

Invest in good tools. If you are into garage sales, you can often pick up excellent well maintained tools very inexpensively but be selective - there is a lot of junk out there. In the end, substandard tools will slow you down and prove extremely frustrating to use. Keep your tools healthy - learn to use a wetstone or grinding wheel where appropriate (screwdrivers, drill bits, etc.) and put a light film of oil (e.g., WD40) on steel tools to prevent rust.

Some basic hand tools.

- * Screwdrivers of all types and sizes including straight, Philips, Torx. Security bits for some video games, PS2s, etc. Notched straight blade for VCR mechanical tracking adjustment - make or buy.
 - * Jewelers screwdrivers - both straight and philips. These are generally inexpensive but quality is also quite variable.
 - * Small socket driver set.
 - * Hex key wrenches or hex drivers. Miniature metric sizes for VCRs.
 - * Pliers - long nose, round nose, curved. Both smooth and serrated types are useful.
 - * Adjustable wrench (small).
 - * Cutters - diagonal and flush. Linesman's pliers.
 - * Wire strippers - fixed and adjustable. Crimp tool.
 - * Alignment tools - (at least a standard RCA type for coils).
 - * Files - small set of assorted types including flat, round, square, and triangular.
 - * Dental picks - maybe a reason to go to the dentist? :-). These are useful for poking and prodding in restricted areas (but you knew that).
 - * Locking clamps - hemostats - for securing small parts while soldering etc.
 - * Magnetic pickup tool - you can never tell when you will drop something deep inside a VCR. If you keep a strong magnet stuck to your workbench, you can use it to magnetize most steel tools such as screwdrivers. Just keep anything magnetized away from the tape path and magnetic heads.
 - * Hand drill, electric drill, drill press - one or all. A small benchtop drill press (e.g., 8") is invaluable for many tasks. A good set of high speed bits (not the 1000 bits for \$9.95 variety). Also, miniature bits for PCB and small plastic repairs.
 - * Soldering and desoldering equipment. An entire chapter is devoted to this topic with the name, you guessed it: "[Soldering and Desoldering Equipment and Techniq](#)
-

4.2) Basic test equipment

Obviously, you can load up on exotic test equipment. What follows are those that are most used. You might at first not consider all of these to fit the category of test equipment but an old TV can provide as much or more useful information about a video signal than a fancy waveform analyzer in many cases. And, basic reliable easy-to-use test equipment is more important than sophisticated instrumentation laden with features you will never need.

* DMM and/or VOM. I prefer to have both. A good old Simpson 260 is better in many ways than a cheap digital multimeter. For most measurements, I still use a 25 year old Lafayette (remember them?) VOM. I only go for the DMM when I need to measure really low ohms or where better accuracy is needed (though this can be deceptive - just because a DMM has 3-1/2 digits does not mean it is that accurate - check you manual, it may prove enlightening). The Simpson 260 also has a nice 5000 V AC/DC scale which the others lack.

A fancy expensive multimeter is not needed, at least not while you are just starting out (and likely to make some occasional mistakes like attempting to measure line voltage on the ohms scale.) However, if someone offers to give you a nice Fluke DMM, don't turn it down :-).

Scales for transistor, capacitor, frequency counter, etc. are not really essential. A diode test function on a DMM is needed, however, to properly bias semiconductor junctions. Even this is not useful for in-circuit tests or for some power transistors or transistors with built in damper diodes and/or base resistors.

Make sure you have a good well insulated set of test probes. This is for your own safety as you may be measuring relatively high voltages. Periodically inspect for damage and repair or replace as needed. If the ones that came with your multimeter are substandard - flimsy connectors or very thin insulation, replace them as well.

A high impedance high voltage probe is sometimes useful for TVs and monitors. You can build one of these which will suffice for most consumer electronics work.

* AC clamp-on ammeter. This permits the measurement of currents in appliances or electrical wiring without having to cut any wires. At most, you will need an easily constructed adapter to permit access to a single conductor of a line cord. This may be an option for your multimeter.

* Oscilloscope - dual trace, 10 to 20 MHz minimum vertical bandwidth, delayed sweep desirable but not essential. A good set of proper 10x/1x probes. High vertical bandwidth is desirable but most consumer electronics work can be done with a 10 MHz scope. If you get into digital debugging, that is another story - 100 MHz and up will be required. If money is no object, get a good digital storage scope. You can even get relatively inexpensive scope cards for PCs, but unless you are into PC controlled instrumentation, a stand-alone scope is much more useful.

I would recommend a good used Tektronix or Hewlett Packard scope over a new scope of almost any other brand. You will usually get more scope for your money and these things last almost forever. Stay away from bargain basement scopes even if you find one in a dumpster (well almost). My 'good' scope is the militarized version (AN/USM-281A) of the HP180 lab scope. This has a dual channel 50 MHz vertical plugin and a delayed sweep horizontal plug-in. I have seen these going for under \$300 from surplus outfits. For a little more money, you can get a Tek 465, 100 Mhz scope (\$400-700) which will suffice for all but the most demanding (read: RF or high speed digital) repairs.

You don't absolutely need an oscilloscope when you are just starting out in electronics but it would help a great deal. It need not be a fancy one at first especially if you are not sure if electronics is for you. However, being able to see what is going on can make all the difference in your early understanding of much of what is being discussed in the textbooks and the newsgroups. You can probably find something used that will get you through a couple of years for less than \$100. An oldie but goodie is much better than nothing at all even if it isn't dual channel or high bandwidth!

- * Logic probe - for quick checks of digital circuitry for activity. A logic pulsar can be used to force a momentary 1 or 0. Some people swear by these. I consider them of marginal value at best.
- * TV set (color is desirable) and/or video monitor for testing of video equipment like VCRs, camcorders, laserdisc players, etc. I have an old CGA monitor which includes an NTSC input as well.

A great deal of information can be gathered more quickly by examining the picture on a TV or monitor than can be learned from the video waveform on displayed on a scope.

- * VCR or other video signal source for testing of video monitors and TVs. These will have both RF (F connector) and baseband (RCA jacks) outputs.
- * Stereo tuner or other audio signal source for testing of audio equipment.
- * Audio signal generator. A function generator (sine, square, triangle) is nice as well. The usual audio generator will output from a few Hz to about 1 MHz.
- * Audio amp connected to a loudspeaker. The input should be selectable between line level and mic level and be brought out through a shielded cable to a test probe and ground clip. This is useful for tracing an audio circuit to determine where a signal is getting lost.
- * Signal injector. A readily accessible portable source of a test tone or other signal (depending on application) that can be introduced into the intermediate or early stages of a multistage electronic system.

For audio, a simple transistor or 555 timer based battery powered oscillator can be built into a hand held probe. Similar (but generally more specialized) devices can be constructed for RF or video testing.

- * RF signal generator. For serious debugging of radio and tuner front-ends. These can get quite sophisticated (and expensive) with various modulation/sweep functions. For most work, such extravagance is unnecessary.
- * LCR meter - a capacitor tester is desirable but I prefer to substitute a known good capacitor rather than trusting a meter which will not test under the same conditions as exist in-circuit.
- * Adjustable power supplies. At least one of these should be of the totally indestructible variety - one you can accidentally short out without fear of damage. Mine is a simple 1 amp 0-40 V transformer and rectifier/filter cap affair with a little Variac for adjustment.
- * The following book has a number of simple test equipment projects you can build with readily available parts:

Test Equipment Projects You Can Build
Delton T. Horn
Tab Books, a division of McGraw-Hill, Inc., 1992
Blue Ridge Summit, PA 17214
ISBN 0-8306-4154-8 (hardcover), 0-8306-4155-6 (paperback)

4.3) So you can't afford a \$20,000 transient event recorder?

You know the situation - an intermittent that happens once an hour for 1/2 second! In industry, you would use a fancy logic analyzer with associated digital scope to capture the event.

However, there may be no need for such extravagance. If you have an oscilloscope and camcorder or video camera/VCR, you probably have all that is needed.

For a TV or monitor, point the camera at the CRT and the scope screen so that they are both in the picture and record on a 6 hour tape. Then, when your event takes place, you have a permanent record!

That old video camera will be perfectly adequate. It doesn't need a 100X digitally stabilized enhanced reprocessed zoom or 1/10,000th second shutter. It doesn't even need to be color!

Sure, this won't capture the 1 ns glitch. But, for the occasional flash in the picture, it is more than adequate to eliminate a video signal line as the source of the problem.

Extensions to more convoluted problems are left as an exercise for the student!

4.4) Transformers - isolation and variable

Isolation transformers are *essential* to safely work on many types of equipment with exposed AC line connections or live chassis. Variable transformers provide a convenient way to control the input voltage to equipment to determine whether a fault still exists or to evaluate performance at low or high line voltage.

4.5) Isolation transformers

An isolation transformer is very important for safety when working on live chassis equipment. Make it a habit to use an isolation transformer whenever possible. Portions of TVs, monitors, switchmode power supplies, and many other types of equipment are generally fed from a direct connection to the AC line without a power transformer (which would provide the isolation function). The DC power rails will typically be between 150 and 300 V with momentary current availability of multiple amps!

Since earth ground and the Neutral of the power line are connected together at your service panel (fuse or circuit breaker box), grounds like cold water pipes, test equipment chassis, and even a damp concrete floor make suitable returns for the line voltage (Hot or live wire). Since this is just as true with the conductor being a wire or your body, such a situation is very dangerous.

An isolation transformer as its name implies provides a barrier such that accidental contact with an earth ground results in negligible current flow (only due to the parasitic capacitance and inductance of the transformer) - a slight tingle at worst. This also protects your test equipment as well as the device you are troubleshooting since a similar accidental contact can result

in a short circuit, sparks, smoke, and many destroyed parts.

The schematic for a typical isolation transformer is shown below:

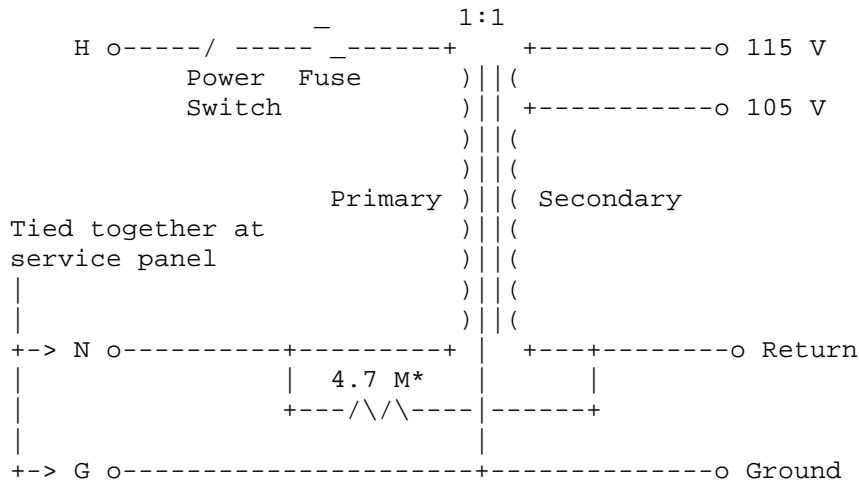

Note: Ground is included on the secondary side. This is actually needed for safety with certain types of equipment like microwave ovens where the HV return is to the chassis. Most other consumer electronics equipment and appliances will only have a 2 wire cord and thus not use the Ground.

Even though the power line Neutral and Ground wires are tied together at the main service panel (fuse or circuit breaker box), the transformer prevents any significant current flow between any of its outputs and earth ground should a fault occur.

The resistor (*) is desirable to permit any static charge to leak off to ground. Since it is quite large - 2 M ohms - no perceptible current will flow between the secondary and primary sides but this value is low enough to dissipate any static charge. CAUTION: The resistor must be a high voltage rated type (as in 4,200 V isolation, large size light blue color to assure that arc over will not result due to voltage differences that may be present when the isolation transformer is being used in its normal manner.

Isolation transformers can be purchased or constructed from a pair of similar power transformers connected back-to-back. I built mine from a couple of old tube-type TV power transformers mounted on a board with an outlet box including a fuse. Their high voltage secondary windings were connected together. The unused low voltage secondary windings can be put in series with the primary or output windings to adjust voltage. See the section: "[Typical homemade isolation transformer](#)".

For super critical applications like in hospitals where every microamp of leakage counts, special isolation transformers are available (no doubt at equally super cost) which have shielding between the primary and secondary to minimize the inter-winding capacitance and inductance as well. This should not really be necessary for general servicing.

Note: Not all definitions of the term 'isolation transformer' are created equal! For some purposes, this may mean just preventing line born electrical noise from passing to the equipment. So, if you acquire something called an 'isolation transformer' on its nameplate, confirm that the primary and secondary are indeed not tied together by a low resistance. If they are, it can probably be modified for service needs by disconnecting a jumper but it may not have the insulation ratings desirable for high voltage isolation.

4.6) Typical homemade isolation transformer

The schematic for a homemade isolation transformer a pair of back-to-back power transformers from ancient tube-type TVs is shown below:

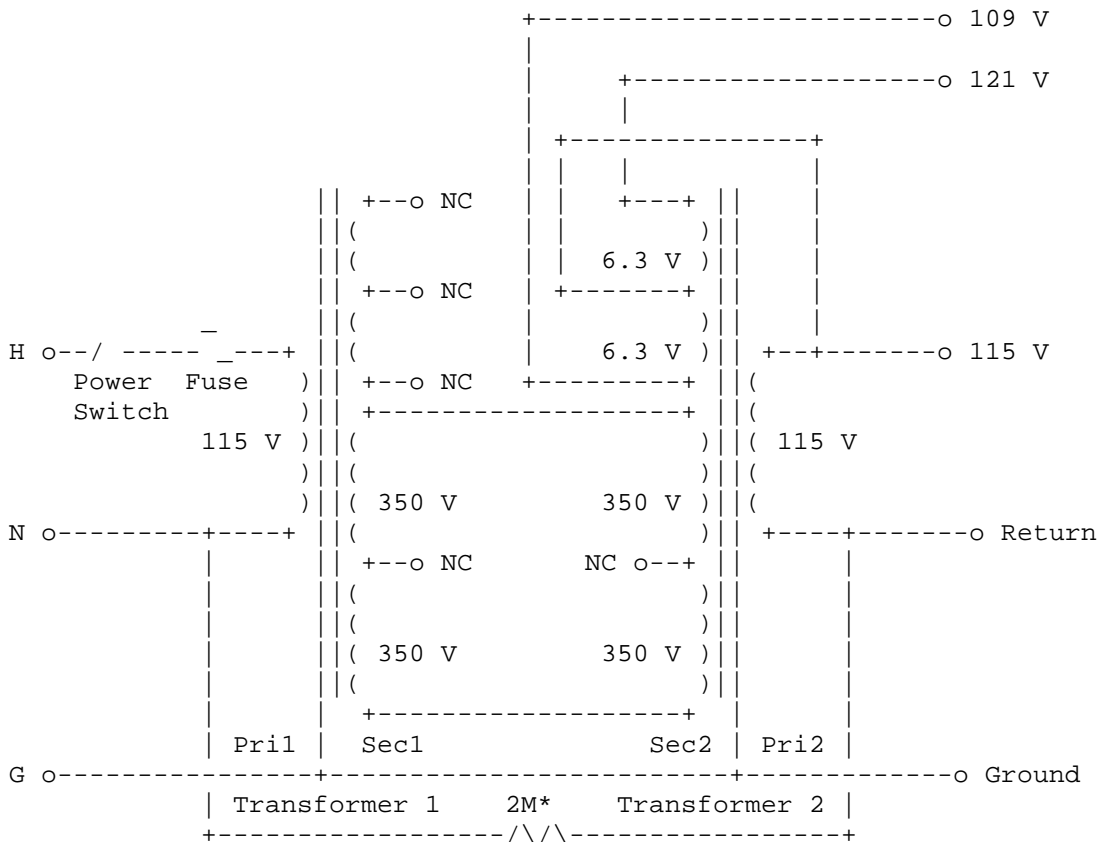

Note that there should be a fuse in the primary to protect against faults in the transformer as well as the load. A slow blow type should be used in the primary circuit. The inrush current of the transformer will depend on the part of the cycle when the switch is closed (worst is actually near the zero crossing) as well as the secondary load. To protect the load, a fast blow type in the secondary is recommended. However, the inrush current of the degauss coils in TV sets and monitors, for example, will often pop a normal or fast blow fuse when no actual problems exist. (It is probably a good idea to disconnect the degauss coils while testing unless they are suspected of being the source of the problem.)

The 2 M resistor (*) is to bleed away any static charge as described above.

Also see the section: "[Isolation transformers from dead microwave ovens](#)".

(From: David Moisan (dmoisan@shore.net)).

It's not as hard as you think to find inexpensive isolation transformers. At the next hamfest, look for someone selling dead UPS's (Uninterruptible Power Sources) or other power conditioning equipment. Isolation transformers are often sold for use in the computer industry; that's how I got mine. 250 VA for \$20, and I could have gotten 1000 VA for \$50 if I wanted. Definitely increases my safety *and* confidence level!

4.7) Isolation transformers from dead microwave ovens

The high voltage transformers from dead microwave ovens (failures are rarely due to the transformers) can also be used. These are probably much easier to locate (try your local appliance repair shop or dump) and will have a nice high capacity - usually 5 to 10 A or more. A pair of these trnasformers can be connected in a similar manner to the tube-type TV power transformers described

in the section: "[Typical homemade isolation transformer](#)". However, there are a few things to keep in mind:

- * These transformers are DANGEROUS. Their high voltage output is between 1,500 and 3,000 VRMS at AMPS - an instantly deadly combination. Therefore, thoroughly insulate the connections between the HV secondaries.
- * The high voltage returns are connected to the cores so these must be tied together AND to earth ground for safety.
- * These transformers may not be rated for continuous duty operation. So, they should probably not be left plugged in when not in use.
- * The more limited capacity of a small isolation transformer can sometimes protect you from yourself - preventing the burnout of a horizontal output transistor due to excessive load or carelessness. You will have no such guardian looking over your shoulder with a microwave oven monster!

A better way to use these is to take the primary (low voltage) windings from two similar transformers and mount them on a single core. Then, there is no high voltage to worry about, the unit is more compact and lighter in weight, and the performance is better (less voltage droop at high loads). Of course, disassembling the cores may prove interesting especially if they were originally welded!

4.8) How safe is a homemade isolation transformer?

Some people will claim that because it is homemade from salvaged parts, it *cannot* be as safe as a commercial unit.

Keep in mind that I am not talking about using something that has been rusting away in a damp basement for 20 years. The power transformers from tube-type TVs or audio amplifiers must have been designed with isolation requirements in mind to obtain regulatory approval in the first place since they are used in equipment where the user may come in contact with metal parts.

Also, the use of an isolation transformer is no excuse to ignore the other aspects of safe troubleshooting.

It is easy to test for AC and DC leakage - and this should be done - to be sure that your transformers are in good condition. With two transformers, the probability of a failure is even smaller - $1/(P*P)$. Personally, I would trust the homemade transformer over a cheap import any day!

4.9) Variable autotransformers

A variable autotransformer (Variac is the trade-name of one popular brand) enable the AC input to an appliance or piece of electronic equipment to be easily varied from 0 to full (or greater than full) line voltage. Your first Variac doesn't need to be large - a 2 A unit mounted with a switch, outlet and fuse will suffice for most tasks. However, a 5 amp or larger Variac is desirable. If you will be troubleshooting 220 VAC equipment in the US, there are Variacs that will output 0 to 240 VAC from a 115 VAC line. WARNING: A Variac is NOT an isolation transformer!

The internal wiring of a typical Variac is shown below:

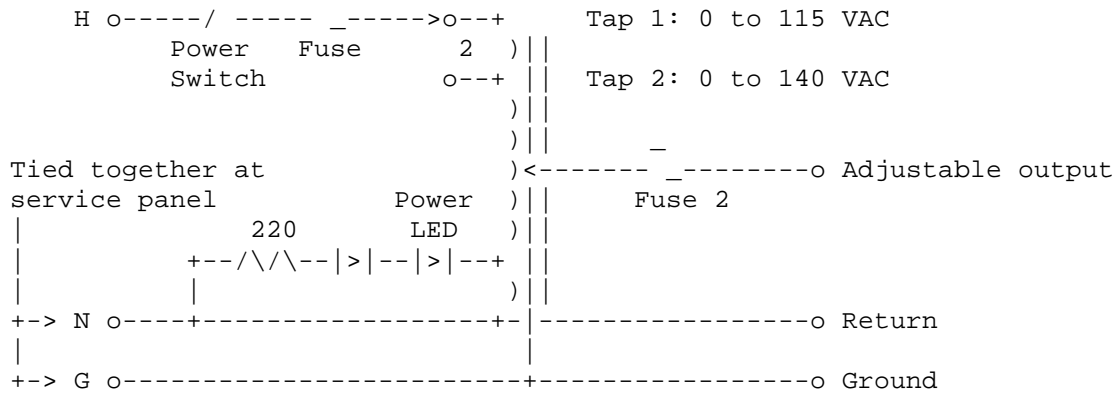

Warning: Direct connection between input and output - no isolation since the power line Neutral and Ground are tied together at the main service panel (fuse or circuit breaker box)!

Note: the 'Power LED' circuit is soldered directly to a winding location determined to produce about 6 VAC.

4.10) Variable isolation transformers

This should probably be your basic setup for troubleshooting. You don't need to buy a fancy combination unit. A Variac can be followed by a normal isolation transformer. (The opposite order also works. There may be some subtle differences in load capacity.)

4.11) Variac/isolation transformer with current limiting

For the well equipped troubleshooter, there are also devices (Variacs and/or isolation transformers or combos) with adjustable (electronic) current limiting. This is particularly useful to protect the equipment being tested from excessive current - somewhat like the series light bulb but easily settable for each particular situation.

4.12) What about the scope ground?

In general, scopes SHOULD be earth grounded. The only time this is not the case is if you are attempting to measure signals in a line-connected device such as found in many TVs and switching power supplies and are not using an isolation transformer. However, this is a very dangerous setup and should be avoided if at all possible. With line-connected equipment, the return or ground reference is not at earth ground potential due to the bridge rectifier or voltage doubler often used in the power supply front-end.

Without an isolation transformer, connecting the scope ground clip to the return will result in a short through the ground lead between the equipment and earth ground. There will be smoke and possibly blown components as well. Disconnecting the scope from ground allows its case to float which will prevent the melt-down but is EXTREMELY DANGEROUS since the entire scope cabinet is effectively connected to the power line. You (or someone else not familiar with your foolishness) may casually touch or lean against the scope cabinet and be thrown across the room if it is a lucky day or worse. Don't do it!

Invest in an isolation transformer. It is very cost effective insurance.

4.13) Basic Ancillary Equipment

Various common items are useful for testing of the following consumer electronics and computer devices. These will normally be used before and during use of any actual test equipment. (Some of these were already listed under the heading of 'test equipment'). However, this is kind of inverted identifying what is needed for each type of equipment being repaired.

- * TVs: VHF and UHF antennas and/or VCR or other video source with both RF and baseband (RCA plugs) outputs.
- * VCRs: a small TV (preferably color but a monochrome TV will suffice for many tests) and/or NTSC/PAL video monitor, antenna, known good video tapes at both SP and SLP speeds. Also, a couple of blank cassettes for record tests.
- * Camcorders: same as VCRs but in addition, a test chart, tripod, and lamps for indoor testing.
- * CD and Laserdisc Players: - a garbage CD and test CD (or laserdiscs). A garbage disc is one you do not care about if it gets scratched. A test disc does not need to be an official (and expensive) test disc - any known good disc will do for most tests. The garbage CD can even be an outdated CDROM - an audio CD player will often read the directory of a CDROM just like an audio CD.

Special cut-down miniature test CDs can be made to view the lens motion while focusing and to permit access to adjustments blocked by normal CDs in many portable players. See the document: "Notes on Troubleshooting and Repair of CD Players and CDROM Drives" for details.

An IR detector will be needed to confirm laserdiode operation.

An audio amplifier with speakers or headphones will be needed for the audio tests, or headphones if the unit has a headphone jack. A TV or video monitor will be needed for Laserdisc video tests.

- * Audio Equipment - a set of known working stereo components consisting of at least a tuner, amplifier, and speakers. Headphones are also useful. For most purposes, an inexpensive setup is preferred since there is no telling what kind of abuse it may need to endure during troubleshooting. I suppose that a turntable may even be needed occasionally. A couple of prerecorded audio cassettes are handy when testing tape decks. One of these should have a tone of known frequency recorded on an accurately calibrated deck for setting tape speed. Also, a couple of blank cassettes for record tests.
- * Microwave Ovens - a cup of water for a load. You don't need special microwave approved water - tap water will do :-). A thermometer for power tests. Neon or incandescent bulbs with their leads shorted together can serve as microwave detectors inside the oven (though these may not always survive for very long).
- * PCs and components - a working basic PC is useful to serve as a testbed for trying suspect components. I use an old 286 mainboard with just enough to boot from an old hard drive. A set of known working basic PC peripheral boards is useful - SA, IDE and MFM HD and FD controller, I/O ports, sound card and speakers, 5-1/4" and 3-1/2" floppy drives, etc. A spare power supply - even one that is not an exact mechanical match - is also handy for testing. An old laptop (commonly used as a door stop) is useful for testing

printers on location.

- * Computer Monitors - a test PC is useful as a video source. Of course, it will need to support whatever scan rates and video types the monitor is designed to accept. Programs are available to display purity, convergence, focus, color, and other test patterns.
- * Telephones, answering machines, faxes - a phone line simulator is useful for initial tests. For many purposes, a DC power supply or battery and 600 ohm resistor will be all you need. A pair of normal phone lines will of course also work but you will need to provide jacks where you are working and access (which may be difficult with teens in the house).

4.14) Incredibly handy widgets(tm)

These are the little gadgets and homemade testers that are useful for many repair situations. Some of these can also be purchased if you are the lazy type. Here are just a few of the most basic:

- * Series light bulb for current limiting during the testing of TV sets, monitors, switching power supplies, audio power amplifiers, etc. I built an outlet box with two outlets wired in series, switch, and indicator. A lamp or other load can be plugged into one outlet and the device under test into the other. Clearly label the special outlet box so you (or someone else) will not attempt to use it for other purposes!

A typical schematic is shown below:

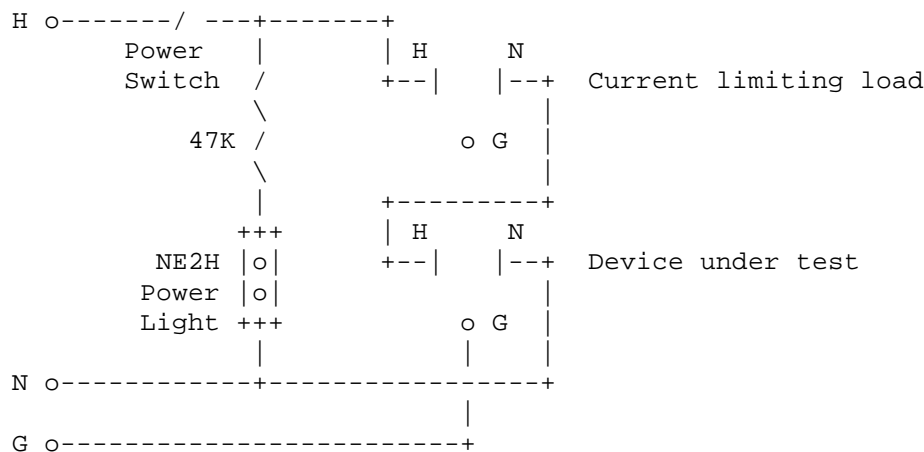

Note: Ground connections normally not used for equipment likely to be tested using this device.

See the repair guides for specific equipment for more details on the use of the series light bulb.

- * Capacitor discharge tool. This device provides a safe and low stress (for your spouse - no zap) way of discharging the capacitors found in TV sets, monitors, microwave ovens, electronic flash units, etc. An indicator can easily be built in as well to provide a visual confirmation as the voltage decays.

Safety note: always double check that capacitors are fully discharged with a voltmeter before touching any high voltage terminals!

See the document: "[Testing Capacitors with a Multimeter and Safe Discharging](#)" for additional information.

- * Video cassette cheater. This is the shell of a VHS or Beta cassette with

all of the innards removed and most of the top and bottom cut out to permit access to the reel spindles and other rotating components of a VCR during operation. You can also purchase these at grossly inflated prices.

See the document: "Notes on Troubleshooting and Repair of Video Cassette Recorder (VCR)" for additional construction details.

- * Degaussing coil. Make or buy. The internal degaussing coil salvaged from a defunct TV doubled over to half its original diameter to increase its strength in series with a 200 W light bulb for current limiting, (use the series light bulb widget for this), fuse, and momentary switch will work just fine.

See the document: "Notes on Troubleshooting and Repair of Television Sets" for additional information on CRT magnetization and degaussing techniques.

- * Tape head demagnetizer. This could just be a coil wrapped around a common nail with its end protected with tape. Connect to low voltage AC. However, these are so inexpensive that you should just buy one.

See the documents: "Notes on Troubleshooting and Repair of Audio Equipment and other Miscellaneous Stuff" and "Notes on Troubleshooting and Repair of Video Cassette Recorder (VCR)" for additional information on tape head demagnetizing.

Caution: do not use a demagnetizer on video heads unless specifically designed for them. Some are strong enough to damage the fragile ferrite cores. Video heads generally do not require demagnetizing anyhow.

- * IR detector. This can be a photodiode/LED circuit or IR sensitive card. Use for testing remote controls, IR LEDs in photosensors, and CD laserdiodes.

See the document: "Notes on Troubleshooting and Repair of [Hand-held IR] Remote Control" for construction details.

- * Flyback tester. I use a 12 V chopper with a 10 turn coil to excite the flyback under test. This will identify most primary and secondary short type faults under near-operating conditions.

See the document: "[Testing of Flyback \(LOPT\) Transformers](#)" for additional information.

- * High voltage probe for your multimeter. This will come in handy when testing the high voltage circuits of TVs, monitors, and microwave ovens (though extreme care will be needed, particularly with the latter). See the document: "[Simple High Voltage Probe design](#)" for details on basic high voltage probes you can construct from (relatively) readily available parts. These will be satisfactory for DC voltages but compensation to get any kind of high frequency response can be tricky. However, that will handle most consumer electronics needs.

- * Not-so-fantastic current probe. When diagnosing TV and monitor deflection problems, a current probe may be desirable to view the current waveforms in the yoke and flyback. You cannot view the high voltage signals without a high frequency high voltage probe.

If you have a current probe for your scope, this can be used to monitor the various current waveforms. I have used my Tektronix current probe to view the yoke current on TVs. The rendition of the horizontal deflection current waveform is quite good. However, the vertical suffers from severe distortion due to the low frequency cutoff of this probe.

You can build a not-very-fantastic (but quite usable) current problem using a split ferrite core of the type used on keyboard and monitor cables (preferably one that snaps together). The following will work:

- Wrap seven turns of insulated wire around one half of the core.
- Solder a 2.2 ohm resistor across the two leads to act as a load.
- Connect to the vertical input of your scope via a coaxial cable or probe.

You can experiment with the number of turns and load resistor value for best results.

To use your fabulous device, insert one and only one of the current carrying wires inside the ferrite core and clamp the two halves together.

For a typical TV horizontal deflection yoke, this results in about a .3 V p-p signal. The shape was similar to that from my (originally) expensive Tektronix current probe. Enjoy the show! Due to its uncompensated design, this simple probe will not work well for low frequency signals.

- * Quick and dirty curve tracer. A curve tracer is useful for displaying the I-V characteristics of semiconductor and other devices. See the sections on curve tracer design in the document: "[Basic Testing of Semiconductor Devices](#)".

There is info on useful devices for your scope that you can construct in about 10 minutes. These won't replace a fancy Tek 576 but may be all you need (or at least can justify on a finite budget).

- * Handy-dandy phone line tester. The inexpensive variety is just a pair of LEDs in series with a resistor for each line attached to an RJ11 connector. However, this is much more convenient than fumbling with a multimeter! You can buy one at Radio Shack (about \$7) or easily build your own. See the document: "[Notes on the Troubleshooting and Repair of Audio Equipment and other Miscellaneous line tester](#)" for details.

4.15) Miscellaneous

- * Clip leads. Like woodworking clamps, you can never have too many of these.
- * Patch cords for audio, video, and telephone interconnection.
- * Parallel (Centronics) printer, serial (breakout box desirable), other computer cables.
- * Insulating sheets - for separating circuit boards when removed from the chassis. These can be cardboard, fiberglass, plastic, etc.
- * Insulating sticks - for prodding to locate intermittents.
- * Small parts tray and container. I always use a film canister or pill bottle for storing the screws, washers, and springs removed during disassembly. An icecube tray or egg carton makes a handy parts bin for temporary storage of small parts while you are working.

4.16) Making a bench power supply from a PC power supply

The power supply from a long obsolete PC can be the basis for a low cost unit useful for a variety of design and troubleshooting applications. The typical 200 W PC power supply will provide +5 V at 20 A, +12 at 8 A, and low current -5 V and -12 V outputs. However, these are not that well filtered - at least not where low noise analog circuits are concerned. They are fine for digital and power circuits as is. For analog work, additional post regulation (e.g., LM317s) and filtering may be needed.

* Typical (but not always) color codes for PC power supplies:

Red: +5, Yellow: +12, Black: Gnd (Probably case as well).
White: -5, Blue: -12, Orange: Power_good (output).

(Some newer supplies may have a +3.3 output as well which may be green).

* PC power supplies (as well as most other switchers) need a minimum load on +5 and possibly on +12 as well. An amp (e.g., 5 ohms on +5) should be enough.

I use an old dual beam auto headlight. It adds a touch of class as well to an otherwise totally boring setup :-). You can also use auto tail light bulbs or suitable power resistors or old disk drives you don't really care about (you know, those boat anchors).

* There are no sense lines. There is a 'Power_Good' line which is an output from the power supply to the mainboard and can be ignored unless you want to connect it to an indicator to let you know all the outputs are within specs (it may need a pullup and I don't know its drive capability).

* Pinout for the standard PC and clone connector (some companies like Compaq do NOT use this type of connector, however.). Black (Gnd) wires together for the P8 and P9 connectors when installed to mainboard.

J8: Pin 1 = Power_Good	J9: Pin 1 = Gnd
Pin 2 = +5	Pin 2 = Gnd
Pin 3 = +12	Pin 3 = -5
Pin 4 = -12	Pin 4 = +5
Pin 5 = Gnd	Pin 5 = +5
Pin 6 = Gnd	Pin 6 = +5

Note: for an XT only, J8-Pin 1 is Gnd, J8-Pin 2 is no connect.

* The peripheral connectors are: Pin 1: +12, Pin 2 and 3: Gnd, Pin 4 = +5.

Chapter 5) Soldering and Desoldering Equipment and Techniques

5.1) Solder is not glue

The ease and quality of your work will depend both on proper soldering as well as desoldering (often called rework) equipment.

However, the purpose of solder is not to physically anchor connections - they must be mechanically secure first to assure reliability. When properly done, solder actually combines with the clean metal surface of the wires, pins, and terminals assuring a low resistance connection.

While there are several conditions must be satisfied to achieve good reliable solder connections, with a little practice, soldering will become essentially automatic and you will know immediately when the results are satisfactory.

There have been entire handbooks written on proper soldering technique. Organizations like NASA take this seriously - after all, a service call to the one of Jupiter's moons would be quite costly!

Additional information on soldering techniques and equipment can be found at:

* <http://www.epemag.wimborne.co.uk/solderfaq.htm>

5.2) Soldering equipment

- * A low wattage (25 W) iron for delicate components including discrete semiconductors, ICs, other small parts).
- * A medium wattage (40-50W) iron for heavy duty circuit board work including power components, power plane connections, and large transformers).
- * A 100-140 W soldering gun for chassis connections.

Three wire grounded soldering equipment is recommended but I do not consider it essential for this type of repair work. However, a temperature regulated soldering station is a really nice piece of equipment if you can afford it or happen on a really good deal.

I consider fine gauge rosin core solder (.030 or less) to be best for most applications (e.g., Ersin Multicore).

- * Desoldering pump - SoldaPullit or similar 'solder sucker' for removing components easily and usually nondestructively. SolderWick is also handy for cleaning up desoldered connections.

A vacuum rework station is not needed unless you are removing your soldered in 500 pin Intel P6!

5.3) Soldering techniques

Soldering is a skill that is handy to know for many types of construction and repair. For modern small appliances, it is less important than it once was as solderless connectors have virtually replaced solder for internal wiring.

However, there are times where soldering is more convenient. Use of the proper technique is critical to reliability and safety. A good solder connection is not just a bunch of wires and terminals with solder dribbled over them. When done correctly, the solder actually bonds to the surface of the metal (usually copper) parts.

Effective soldering is by no means difficult but some practice may be needed to perfect your technique.

The following guidelines will assure reliable solder joints:

- * Only use rosin core solder (e.g., 60/40 tin/lead) for electronics work. A 1 pound spool will last a long time and costs about \$10. Suggested diameter is .030 to .060 inches for appliances. The smaller size is preferred as it will be useful for other types of precision electronics repairs or construction as well. The rosin is used as a flux to clean the metal surface to assure a secure bond. NEVER use acid core solder or the stuff used to sweat copper pipes! The flux is corrosive and it is not possible to adequately clean up the connections afterward to remove all residue.

- * Keep the tip of the soldering iron or gun clean and tinned. Buy tips that are permanently tinned - they are coated and will outlast countless normal copper tips. A quick wipe on a wet sponge when hot and a bit of solder and they will be as good as new for a long time. (These should never be filed or sanded).
- * Make sure every part to be soldered - terminal, wire, component leads - is free of any surface film, insulation, or oxidation. Fine sandpaper or an Xacto knife may be used, for example, to clean the surfaces. The secret to a good solder joint is to make sure everything is perfectly clean and shiny and not depend on the flux alone to accomplish this. Just make sure the scrapings are cleared away so they don't cause short circuits.
- * Start with a strong mechanical joint. Don't depend on the solder to hold the connection together. If possible, loop each wire or component lead through the hole in the terminal. If there is no hole, wrap them once around the terminal. Gently anchor them with a pair of needlenose pliers.
- * Use a properly sized soldering iron or gun: 20-25 W iron for fine circuit board work; 25-50 W iron for general soldering of terminals and wires and power circuit boards; 100-200 W soldering gun for chassis and large area circuit planes. With a properly sized iron or gun, the task will be fast - 1 to 2 seconds for a typical connection - and will result in little or no damage to the circuit board, plastic switch housings, insulation, etc. Large soldering jobs will take longer but no more than 5 to 10 seconds for a large expanse of copper. If it is taking too long, your iron is undersized for the task, is dirty, or has not reached operating temperature. For appliance work there is no need for a fancy soldering station - a less than \$10 soldering iron or \$25 soldering gun as appropriate will be all that is required.
- * Heat the parts to be soldered, not the solder. Touch the end of the solder to the parts, not the soldering iron or gun. Once the terminal, wires, or component leads are hot, the solder will flow via capillary action, fill all voids, and make a secure mechanical and electrical bond. Sometimes, applying a little from each side will more effectively reach all nooks and crannies.
- * Don't overdo it. Only enough solder is needed to fill all voids. The resulting surface should be concave between the wires and terminal, not bulging with excess solder.
- * Keep everything absolutely still for the few seconds it takes the solder to solidify. Otherwise, you will end up with a bad connection - what is called a 'cold solder joint'.
- * A good solder connection will be quite shiny - not dull gray or granular. If your result is less than perfect reheat it and add a bit of new solder with flux to help it reflow.

Practice on some scrap wire and electronic parts. It should take you about 3 minutes to master the technique!

5.4) Desoldering techniques

Occasionally, it will be necessary to remove solder - either excess or to replace wires or components. A variety of tools are available for this purpose. The one I recommend is a vacuum solder pump called 'SoldaPullet' (about \$20). Cock the pump, heat the joint to be cleared, and press the trigger. Molten solder is sucked up into the barrel of the device leaving the terminal nearly free of solder. Then use a pair of needlenose pliers and a dental pick to gently free the wires or component.

For stubborn joints or those connecting to the power planes (surface or multilayer boards), you may need to add some fresh solder and/or flux and then try again. Generally, if you only get part of the solder off the first time, repeated attempts will fail unless you add some fresh solder.

Other approaches that may be used in place of or in addition to this: Solder Wick which is a copper braid that absorbs solder via capillary action; rubber bulb type solder pumps, and motor driven vacuum solder rework stations (pricey).

5.5) Nick's comments on successful desoldering techniques

These directly apply to the destructive (i.e., you don't care about saving the part) removal of IC chips. However, the basic techniques work for discrete parts as well.

(From: Nicholas Bodley (nbodley@tiac.net)).

A few points to keep in mind...

Try to get cutters that will let you snip individual leads on the IC. Get tool catalogs! I like Contact East, in the USA; not sure about Canada. Jensen, in Arizona, I think, tends to be costly.

If you snip all the leads on one side, you can bend the IC back and forth to break the other side free, but be sure to do the bending next to the plastic (it's harder to do there).

When you cut the IC leads, do your best to leave most of each lead sticking up above the surface of the board.

Set your iron to about 770 deg. F (400 deg. C). (This assumes a modern soldering station with a temperature control, and a relatively-slender tip.) Be sure that the tip is clean and shiny and properly tinned. Any oxidation is just no good. (DON'T file modern plated tips! You'll remove the plating!). Be fanatical about ensuring that the tip always idles with a decent coating of solder.

Hotter temps run a real risk of spoiling the adhesive bond that holds the copper foil to the board. DO NOT use a higher temp to make up for an improperly-tinned tip!! (You might need a higher temp for holes in the middle of ground planes, however. These will sink the heat away effectively; but do those separately.)

You must get each pad hot enough to be well above the melting point, so that the cold air won't make the solder resolidify when you slurp it up.

To transfer enough heat, you must have a fillet of solder between the tip and the pad. If necessary, add a bit of solder to ensure this!

After hitting these points so hard, I'll relax and say that you'll really do better if you remove each lead stub individually with assembly tweezers (AA style are good) or thin needle-nose pliers.

Once they're all out, then you need to be concerned about heating the pads enough. Now you can desolder. The other messages in this post have good advice on that.

You need to maintain your desoldering tool, too. It might not have good vacuum if ignored.

It's tricky to hold the iron on the pad while getting the nozzle close enough, but a decent desoldering tool will work if tilted somewhat to let the tip contact the pad.

If a hole doesn't open, but some solder has been slurped up, you could try good solder wick (Solder-Wick (Soder-Wik?) brand is good); it can sometimes pull up solder from underneath by capillary action. (I didn't believe this until it happened!) Poor solder wick isn't fluxed sufficiently, or might be subtly corroded. It should soak up solder like a sponge.

It might be quicker to refill the hole with a bit of solder and repeat; there could be a good blob of it on the other side, which you might, or might not, be able to get to.

(If you can get to both sides, and have five hands, you could apply heat to one side, let the tip dwell for a few seconds to melt all the solder, and slurp from the other side.)

If things become messy, apply liquid flux (seems not to be too easy to find in small quantities; I use a flux pen, which seems not overpriced). Reheat the pad, and the flux should do a great job of tidying things up. It tends to let capillary action make the holes open wider, when most of the solder has been picked up.

I think it's well worth the effort to cut the leads free from the IC body and remove them one at a time, then go over the pads a second time to remove the solder.

I have very recently removed a 16-pin DIP twice from a location without damaging the pads at all by these principles.

It's much harder, or impossible, to do good work with poor tools. Do try to get good tools, and learn to take care of them.

5.6) Soldering pins in plastic connectors

The thermoplastic used to mold many common cheap connectors softens or melts at relatively low temperatures. This can result in the pins popping out or shifting position (even shorting) as you attempt to solder to them to replace a bad connection, for example.

One approach that works in some cases is to use the mating socket to stabilize the pins so they remain in position as you solder. The plastic will still melt - not as much if you use an adequately sized iron since the socket will act as a heat sink - but will not move.

An important consideration is using the proper soldering iron. In some cases, a larger iron is better - you get in and out more quickly without heating up everything in the neighborhood.

Chapter 6) Supplies and Parts

6.1) Lubricants, cleaning agents, and other liquidy or slimy stuff

- * Light oil such as electric motor oil or 3-In-One. WD40 may be useful for cleaning or freeing rusted screws but it is not a general purpose lubricant despite what is claimed on the label.
 - * Light grease suitable for fine electronics - must be plastic-safe.
 - * Isopropyl alcohol (91 % medicinal or pure).
 - Q-tip swabs for cleaning of everything BUT video heads.
 - Chamois head cleaning sticks for video heads.
- Note that sometimes plain water will work better for sugar based coatings. Tape head cleaner can be used for head cleaning as well.
- * Contact cleaner in spray can. This is used for switches and relays.
 - * Control cleaner in spray can. This is used for potentiometers and will probably include some type of non-drying lubricant.
 - * Tuner cleaner and lubricant in spray can. The stuff sold by Radio Shack works fine.
 - * Degreaser in spray can. Use with care around plastics.
 - * WD40 in spray can. NOT for lubrication in most cases. However, WD40 is an intermediate strength solvent that comes in handy for cleaning, removing labels and label goo, coating tools to prevent rust, etc.
 - * Liquid flux for helping in tough soldering and desoldering jobs.
 - * Flux remover. Isopropyl alcohol will work but there are also spray cans of this stuff.
 - * Silicone heat sink compound. A little goes a long way. You don't need to goop it on - just the thinnest film to fill voids.
-

6.2) Adhesives

- * Two part fast setting Epoxy.
 - * General purpose adhesive like Duco Cement.
 - * Semi-flexible adhesive like windshield sealer.
 - * Flexible adhesive like weather strip cement or silicone sealer or RTV. Note: some types may be corrosive to metals upon curing - test first.
 - * Solvent type plastic cement or plastic model cement.
 - * Rubber cement.
 - * Plastic electrical tape.
 - * Masking tape.
 - * Clear plastic tape.
-

6.3) Electronic sealers and potting compounds

These may be needed to insulate a high voltage connection or to encapsulate a circuit for reliability (or to keep it from prying eyes!).

Ordinary silicone window and bathtub caulk has the right mechanical and electrical properties (tough, flexible, excellent insulator especially for high voltage), but it secretes acetic acid upon curing and this may damage the electronic circuitry (but not always the case). Some types claim to be safe for this or that (e.g., aluminum) but unless it states specifically that it is safe for electronics, use at your own risk.

(From: Ralph L. (ralphl@keycomp.net)).

You can also use an RTV that is safe for oxygen sensors that are used on most computer controlled cars. It does not produce that acetic acid (vinegar smell) during the curing process and will not harm electronics.

(From: Greg Szekeres (gjs@prophet.pharm.pitt.edu)).

Yes, Permatex Ultra Blue is safe, available at most auto parts stores. I have also been using polyurethane instead of silicone, although it has problems with some materials.

(From: RadMan (radcom@comnet.ca)).

DOW makes HYSOL that totally encapsulates the circuits and if you mix the HYSOL with India Ink it becomes opaque and an excellent "poor man's patent".

The circuit should be tested before placing in a mold ready for potting. Some agents require UV to cure, some need heat. You can also try Miller-Stevensen 907 available at Future/Active, and it pots with a heat gun very fast (30 mins).

6.4) Electronic parts

I was going to attempt to make a basic list of recommended parts but this quickly got out of hand. The list below is just a start. The idea is to have enough parts available so that you do not need to raid the local electronics store every time you want to try something.

A good source for many of the basic parts is dead equipment - their organs can live on at your workbench. Parts like small resistors are so inexpensive that this doesn't warrant a lot of time. However, power resistors, potentiometers, power semiconductors, some ICs, etc. are well worth saving. Used electrolytic capacitors will generally still be functional but these do deteriorate with time and heat so testing them first and avoiding the use of really old ones for the permanent repair is probably wise. The majority of my parts inventory is from salvage. Think of them as 'pre-owned burned in components' :-).

- * Resistor assortment. A variety of resistor packs for digital termination.
- * Potentiometers (variable resistors), assorted values.
- * Capacitor assortment - ceramic and electrolytic. Large high voltage electrolytics for power supplies.
- * Rectifiers - 1N4007s for primaries of power supplies. Microwave oven rectifier. Fast recovery rectifiers - for switching supplies.
- * Diodes - 1N4148 signal diodes.
- * Transistors (bipolar): small signal, medium power, high power audio, and horizontal output transistors. Obviously, this list could get quite long. A few basic types will suffice in a pinch.

- * Fuses - 3AG size (1-1/4"x1/4") - .5, 1, 2, 3, 5, 10 amp. You can always solder these across the smaller 5x20 mm fuses often found in consumer equipment these days.
 - * LEDs and indicator lamps.
 - * Wire: assorted colors of #24, #18, and #14 stranded and solid insulated wire. 75 ohm coax for video. Shielded cable for audio. Fine wire (e.g., #30, bare and insulated) for PCB repairs.
 - * Assorted small switches - toggle, pushbutton, etc.
 - * Line cords, plugs, and other electrical components.
 - * Lamp sockets, single and three-way switch/sockets, plugs, etc. for small appliance repair.
 - * Various jacks and plugs such as RCA, phono, F, BNC, etc.
 - * Small loudspeakers, headphones.
 - * etc., etc., etc.
-

6.5) Mechanical parts

- * Hardware assortment including English and Metric screws, nuts, bolts, flat and lock washers.
 - * Split washer assortment. Despite dire warnings to the contrary, these can often be reused. However, they are easily lost.
 - * E-clip and C-clip assortment. These can be reused but very often go 'pling' into never never land when removed.
 - * Spring assortment.
 - * Several thicknesses of steel wire.
 - * Various bits of plastic, wood, and metal to fabricate splints or other emergency repairs.
 - * Dial cord material.
-

Chapter 7) Sources of Information and General Comments

7.1) References

Each of the repair guides in the "Notes on the Troubleshooting and Repair of" series includes a list of relevant books on servicing. Also check out:

- * Electronic Troubleshooting

7.2) Manufacturer's service literature

Service manuals are available for a great deal of consumer electronics. Once you have exhausted the obvious possibilities or mechanical problems, the cost may be well worth it. Depending on the type of equipment, these can range in price from \$10-50 or more. Some are more useful than others. However, not all include the schematics so if you are hoping to repair an electronic problem try to check before buying.

7.3) Identifying OEM manufacturer - FCC numbers

Only a few manufacturers actually produce the vast majority of consumer electronic equipment. For example, Radio Shack, Magnavox, and Emerson do not make their own VCRs (I can tell you are not really surprised!). House brands are nearly always the products of well known manufacturers identical or very nearly identical to their standard models but repackaged or at least relabeled to reflect the store chain's name and logo. This is one reason why such lower cost products may be a good deal (but not always).

How do you determine the actual manufacturer? For most types of consumer electronics equipment, there is something called an 'FCC ID' or 'FCC number'. Any type of equipment that may produce RF interference or be affected by this is required to be registered with the FCC. This number can be used to identify the actual manufacturer of the equipment.

A cross reference and other links can be found at:

http://www.repairfaq.org/REPAIR/F_FCC_ID.html

7.4) Sams' Photofacts

Sams' (no relation) is Howard Sams & Company who publishes circuit diagrams and service info for just about every TV sold on this planet since the 1940s.

Sams' Photofacts schematics and service literature are published by:

Howard W. Sams & Company
2647 Waterfront Parkway, East Drive
Indianapolis, IN 46214
Customer service: 1-800-428-7267

Howard Sams has a Web site at:

<http://www.hwsams.com/>

You can search this site to determine if they have a folder for your model.

These folders of service information have been published for over 45 years (I don't know for how long but I have a set for a 1949 portable (3 inch) Pilot TV - about as portable as an office typewriter if you remember what

one of those was like) and are generally the best most consistent source of service info for TVs, radios, some VCRs and other consumer electronics. There are some Computerfacts but the number of these is very limited. The VCRfacts are also somewhat limited and the newer ones tend to have strictly mechanical information.

Sams' Photofacts are often available (for photocopy costs) from your local large public library which may subscribe to the complete series. If not, a large electronic distributor can order the selected folder for you.

One advantage of the Sams' info is that it is compiled in a very consistent format so that once you are familiar with one model TV, it is easy to transfer that knowledge to any other. They provide waveforms at key locations and DC voltage measurements almost everywhere. Additional info such as IC pin to ground and coil resistances are often provided as well. The manufacturer's service manuals are generally not nearly as complete.

7.5) Inside cover of the equipment

Television sets and even old radio often have some kind of circuit diagram pasted inside the back cover. In the old days, this was a complete schematic. Now, if one exists at all, it just shows part numbers and location for key components, occasionally some test points and voltages - still very useful. Some TVs - as late as 10 years ago, maybe even now - included a complete schematic with the product information and owner's manual. I have a 1984 Mitsubishi which came with a very nice high quality multi-page schematic. This is, however, the exception rather than the rule anymore.

Microwave ovens almost always have a schematic diagram of the microwave power generation circuitry pasted inside the sheetmetal cover. This will always include the high voltage transformer, interlocks, rectifier, capacitor, and magnetron. Since most microwave oven problems are in these areas, this is all you are likely to need. The controller, especially electronic units, is often omitted or only covered superficially.

7.6) Additional sources for service information and manuals

(From: William E. Miller (eagle@trader.com)).

* William E Miller We Help Find Antiques and Collectibles
Eagle@trader.com `YourAds!' We Can Search 1 Million Classified Ads
1 (317) 831-0896 <http://www.trader.com/users/5010/5491/>

"We Help Find, Buy, Promote & Sell - Almost Anything, Almost Anywhere"
TV Repair Woes? Get the Sams Photofact TV Service Manual. \$7 Postpaid!

Besides the used Sams TV Repair Manuals I sell, here are a few good sources for various flavors of service manuals.

* Howard W. Sams
Phone (800) 428-7267
<http://www.hwsams.com/>

They have a web site with an online database for searches. They sell manuals for TV (mainly --- sam), VCRs, stereos, computers, monitors, etc.

* A.G. Tannenbaum

Electronic Service Data
P.O. Box 386, Ambler, PA 19002
Phone (215) 540-8055, Fax (215) 540-8327
E-Mail: k2bn@agtannenbaum.com
Web: (coming soon)

"Parts and Service Data, 1920s to the present". Lotsa stuff!

* Michelle Troutman
E-Mail: ai495@yfn.ysu.edu.

She has various manuals for sale.

* Marty Gasman
E-Mail: mgasman@tiac.net.
Web: <http://www.tiac.net/users/mgasman>

He has a LOT of AUDIO service manuals for sale.
Check his full list at his web site.

* John Gallawa
E-Mail: mtek@gulf.net
Web: <http://www.gallawa.com/microtech/>

"We will be happy to help anyone who needs a schematic or parts breakdown for virtually any make and model (commercial or residential) microwave oven."

* Mauritron Technical Services
Phone: 01844-351694
E-Mail: mauritron@dial.pipex.com
Web: <http://dialspace.dial.pipex.com/mauritron/>

"Suppliers of Technical Books and Servicing Information to the television, video and computer repair trade"

Test equipment (and maybe other) manuals:

* Tech Systems, 1-800-435-1516
* Synergetics Surplus, 1-520-428-4073
* Pepper Systems, 1-214-353-0257.
* [Manuals Plus](#), 1-801-882-7188.
* US Surplus, 1-410-750-1083

7.7) Canadian schematics source

(From: John R. Hepburn (jhepburn@recorder.ca)).

I use source in Canada for cheap schematics. I have to mention that they have limited coverage in the last while due to some O.E.M. holdbacks. There is nothing at all on monitors. It is:

* R.C.C. (Radio College of Canada)
Lewcor Communications
Phone: 416-971-4170, Fax# 416-971-4173
Email: lewcor@hookup.net

What they do cover is inexpensive, typically 5 schematics + data in one \$19.50 manual (\$14.00 U.S.). An example, I just received a manual the other day that I ordered to service a Sony VCR. It contained the following.

1. Citizen TV model JCTV-0204/JCTV-3097
2. Citizen VCR model JVHS-3931
3. Hitachi TV model CY07 C#G9LXU1M

4. Hitachi VCR model VT-M262A
5. Sony VCR models SLV-340/380/440/441

I suggest ordering their master index. They have 2 of them, pre-1973 and 1973 to present. You will need it for crossing anyway and it will give you a better idea what value their resources will be to you. Cost for an index is \$5.00 (Can).

7.8) Reverse engineered schematics

A number of companies are in the business of generating schematics either from samples of the equipment or by 'other means' (which we won't go into). One such company that claims to have over 3,000 such schematics is:

* Bomarc Services
P.O. Box 1113 Casper, Wyoming 82602
Phone: 307-234-3488
Web: <http://w3.trib.com/~rollo/bomcat.htm>

I have no idea of their cost, reliability, quality, or accuracy but this type of source may be worth checking if you are desperate! One risk is that he wants \$5 for catalogs of at most 3 categories from the following before you can order: audio, auto/air/marine, computer, detection, industrial, lighting, medical, phone, power supplies, radar, radio, security, tape/disk, telemetry, television, test equipment, time, toys & games, video, potpourri (misc).

7.9) Mark's approach to finding information

The first skill you need when you want to design something is digging up the databooks. This applies to troubleshooting and repair as well. A well stocked literature shelf (f cabinet) is an invaluable time saver. Don't assume you can get EVERYTHING on the net just yet!

Take the lowly 2N3055 power transistor, for example.... (Most of us have its specs engraved on some radiation-hardened neurons safely tucked away in a forgotten part of our brains but for the freshly minted EE or technician....

(From: Mark Zenier (mzenier@netcom.com)).

Places to look:

The web, at sites for companies that make power transistors.

Good bets would be Motorola (<http://www.design-net.com/>), Philips (<http://www.semiconductors.philips.com/>) Note: only 1 'L' in Philips, and SGS-Thomson (<http://www.st.com/>). (A whole bunch more people make 2N3055s, down to some little 50 employee companies that you've never heard of, but they may not have a web site yet). Or start with one of the web directories like <http://www.xs4all.nl/~ganswijk/chipdir> or Grey Creagers pages on <http://www.scruznet.com/~gcreager>. (Hope I got my spelling right on all those URLs).

The sales rep, sales office, or company literature department. Look in the phone book or on the web page for the phone number of a company or their local or regional sale representative or office. Call them up and ask. It's their job to provide customer support and if you sound like you halfway know what you're doing (saying you're a student works, too) AND it doesn't cost them much (don't get greedy) they'll often be more than willing to send you

information. (These days, it might be a CD-ROM of their whole product line. Cheap, but not that easy to use, IMHO.) If they won't help you, ask them where there is someone who can. Like the nearest distributor.

Electronics distributors. Larger ones often fill the same literature distribution role as the sales rep. Other distributors like Jameco, JDR Microdevices, Future Active sell databooks as a catalog item. Or a local distributor that caters to the walk in trade will have a databook shelf and allow (or have a nominal fee for) photocopies. (The big distributors are closed operations, mostly using phone salesmen and UPS for distribution, visitors aren't necessarily welcome.)

A good library. Like one at a university with an electrical engineering program, or a large city library.

Used book stores, a big unselective 'book dump' often will have a good stock of old databooks. Ones that you can't get from the manufacturer and more. Likewise, electronics surplus stores (most big cities should still have one or two) often have them.

7.10) Parts information and cross references

I have found that one of the most useful single sources for information on semiconductors to be the ECG Semiconductors Master Replacement Guide, about \$6 from your local Philips distributor. STK, NTE, and others have similar manuals. The ECG manual will enable you to look up U.S., foreign, and many manufacturer's 'house' numbers and identify device type, pinout, and other information. These companies are now on the Internet as well but their books (Master Selection Guides) may contain more useful information including some specifications and pinouts. However, there are exceptions and hopefully such information will become more available as time goes on.

Also see the section: "[House numbers](#)".

Here are the current Web sites of these companies:

* NTE (NTE Electronics, Inc).

<http://www.nteinc.com/>

Not generally useful unless you want an NTE part. However, there are a few data sheets. I believe this situation is improving.

* ECG (Philips).

<http://www.ecgproducts.com/>

Currently only product line description, no parts information.

* SK (Thompson Consumer Electronics).

<http://www.inland-electronics.com/skcross/>

Information includes SK equivalent and one line summary of specifications.

(From: Gregg (gregglns@ix.netcom.com)).

"NTE's device numbers are the same as ECG's, and their cross-ref guide can be downloaded from <http://www.nteinc.com/>.

It's free but they do want you to register. If you want to bypass this, go to <ftp://nteinc.com/pub/> and download the windows version of the guide, ntesetup.exe. Don't bother with the dos version; the file named dosdisk2.exe

is bad, and won't unzip."

I am not necessarily recommending using ECG (or other generic) replacements if the original replacements are (1) readily available and (2) reasonably priced. (Note that very often the original replacement part will be less expensive than the equivalent from ECG/SK/NTE. Therefore, it should be used if available.) However, the cross reference can save countless hours searching through databooks or contacting the manufacturers. Even if you have a wall of databooks, this source is invaluable. A couple of caveats: (1) ECG crosses have been known to be incorrect - the specifications of the ECG replacement part were inferior to the original. (2) Don't assume that the specifications provided for the ECG part are identical to the original - they may be better in some ways. Thus, using the ECG to determine the specifications of the parts in your junk bin can be risky.

Note that while Howard Sams of Sams' Photofact fame publishes a semiconductor cross reference manual, it would appear to just be a compilation of the ECG, NTE, SK, and Radio Shack manuals - and much more expensive (\$25 or so).

7.11) Transistor designations

Unfortunately, there is no such thing as a universal part number!

* U.S. made semiconductors used to be mostly of the 'nN' variety - 2N with a 3 or 4 digit number for bipolar transistor, for example. This is called the Joint Electron Device Engineering Council (JEDEC) standard numbering but seems to have been replaced by letter prefixes which may be manufacturer dependent although the same part may be available from multiple sources. These numbers are becoming less common and are rare in consumer electronics.

- * 1N: diodes.
- * 2N, 3N: bipolar transistors.
- * 4N, 5N: optocouplers.

* Many devices in consumer electronic equipment are marked with a letter (A, B, C, D, F, J, K) and a 3 or 4 digit number. Add a '2S' in front of this and the result is likely to be the complete (Japanese) part number (the '2S' is nearly always absent from the package label). You can often use this number to find a suitable cross from ECG. However, most of the common '2S' devices are available from places like MCM Electronics, Dalbani, Premium Parts, and Computer Component Source.

- * 2SA, 2SB: PNP bipolar.
- * 2SC, 2SD: NPN bipolar.
- * 2SF: thyristor.
- * 2SJ, 2SK: FET/MOSFET.

There are many other '2S' prefixes but these are by far the most common.

Suffixes may denote package type or some special feature like an internal damper diode (D, for horizontal output deflection transistors), enhanced gain, special speed sort, etc.

* Less common are designations which look similar to the Japanese 2S numbers (a capital letter followed by a 3 or 4 digit number and optional suffix) but are actually Korean part numbers to which you add a 'KT' (Korean Transistor or Type?) instead of a '2S'. So D998 becomes KTD998. These components typically have a capital 'K' on top in addition to the part number starting with the letter (e.g., A,B,C,D). However, sometimes the only way you will know is that ordering the 2S version gets you a device that isn't even close (like a tiny TO92 small signal transistor rather than the 200 W, TO3 type you expected)!

There may be other examples but these are the exceptions (at least for now).

- * Note that some components (usually ICs) may be labeled in a similar manner (like C4558C which is actually a dual op-amp) but this IS the complete part number - just something else to confuse you!

Aside from the VERY expensive D.A.T.A. semiconductor reference series (don't even ask), which includes virtually all types and flavors of devices, there are various Japanese Semiconductor Reference manuals available through places like MCM Electronics for around \$20. Some of the text may be in Japanese but the relevant data is in English so these are handy if you want more detailed or precise specifications for these devices than provided by cross references such as ECG.

7.12) Surface mount parts

Due to their small size, very little information is printed on the actual package for diodes, transistors, capacitors, and other discrete devices.

- * Resistors are often labeled with 3 or 4 itty-bitty digits where the last one is the multiplier (10 to the Nth power).
- * Capacitors are often totally unlabeled but larger electrolytics may have both capacitance and voltage rating. Non-electrolytic types often have a brown body. Electrolytics may be black, yellow (tantalum), or some other color.
- * Discrete semiconductors can often be identified by the number of pins using an ohmmeter at least in a rough sort of way. However, the only way to determine their specifications (and often even the type) or to find a cross reference for the abbreviated markings like 1A, B2, 2J, is to look them up since there is no logical relationship between the marking and the actual part number (unlike the 2S discrete parts, for example). This can be done if you have the manufacturers databooks or possibly even their abbreviated catalog (e.g., Motorola's "Master Semiconductor Selection Guide". ECG, NTE, and SK do cross a few of these SMT parts but their coverage is not nearly as comprehensive as for normal (through-hole) counterparts.

The Web sites of semiconductor manufacturers may also have some information but this varies widely from company to company.

There is an on-line list at:

- * http://www.repairfaq.org/REPAIR/F_SMD_trans.html

This is also somewhat incomplete.

- * ICs. The only option for many of these is to locate the databook or Web site with the datasheet. Even if the part number is similar to a through-hole version, the pinout may differ. However, common TTL/logic chips and op-amps will usually have identical pinouts and specifications. It is often possible to partially confirm this by checking the location of the power pins or known signal connections.

7.13) House numbers

These are the cryptic numbering like 121-1025 or 113234 that may be the only marking on that critical part you need to replace or identify.

Are house numbers used just to make life difficult?

It certainly seems that way from the perspective of repair. Give me industry standard numbers anyway. However, house numbers are a fact of life.

The house number is what you need to order a replacement from the original manufacturer of the equipment but that may not always be desirable due to the likely high cost and possible difficulty in locating a suitable distributor that carries the manufacturer's replacement parts.

As noted in the section: "[Parts information and cross references](#)", a Master Selection Guide like ECG or NTE may be able to give you some idea of the specifications even if you don't want to use their generic replacement semiconductors. Their web sites have (or should have in the future) some amount of cross reference information for industry standard and house numbers. However, don't expect to detailed IC specifications or even pinouts in most cases there or from the disks they may also offer. The hard-copy Master Selection Guides which these companies sell have been better in the past (though this may be changing) but even these won't give you all the details. However, if you do repair work regularly, these 'telephone book' thickness guides worth the \$4 or \$5 that is charged.

Also see the section: "[Parts information and cross references](#)".

7.14) Generic parts (mostly semiconductors)

ECG (Philips), NTE (NTE Electronics), SK (Thompson), and other offer an extensive selection of discrete devices and integrated circuits which are replacements for thousands of industry standard as well as house numbered semiconductors. Should you consider them? My general feeling is: not unless you have to. They are often more expensive than the parts they replace and quality is not always quite as high as an original standard part. However, in most cases, these parts will work just fine.

Other common components like flyback transformers, belts and other rubber parts, and RF modulators may also be available from these sources but they tend to be used less often and quality may vary even more.

7.15) HP-to-industry standard semiconductor cross-reference

(From: Walter Shawlee 2 (walter2@sphere.bc.ca)).

This will help decode all those odd 1820-xxx numbers!

<http://www.sphere.bc.ca/test>

Also HP and Tek repair parts and equipment on line, plus helpful FAQs and links to all kinds of test gear sites.

We also have a big used equipment site on line for Canadians.

7.16) Internet sources of information

Many manufacturers of electronics equipment are now providing info via the World Wide Web. The answer to your question may be a mouse click away. Perform a net search or just try to guess the manufacturer's home page address. The most obvious is often correct. It will usually be of the form "http://www.xxx.com" where xxx is the manufacturer's name, abbreviation, or acronym. For example, Hewlett Packard is hp, Sun Microsystems is sun, Western Digital Corp. is wdc. It is amazing what is appearing freely accessible via the WWW. For example, disk drive manufacturers often have product information including detailed specifications as well as complete jumper and switch settings for all current and older harddrives.

Tandy (Radio Shack) has a nice web resource and fax-back service. This is mostly for their equipment but some of it applies to other brands and there are diagrams which may be useful for other manufacturers' VCRs, TVs, CD players, camcorders, remote controls, and other devices.

http://support.tandy.com/	(Tandy homepage)
http://support.tandy.com/audio.htm	(Audio products)
http://support.tandy.com/video.htm	(Video products)

In addition to Tandy products, there are a couple Sony models. Furthermore, since Tandy does not manufacture its own TVs, VCRs or camcorders - they are other brands with Realistic or other Radio Shack logos - your model may actually be covered. It may just take a little searching to find it.

7.17) Are there schematics of consumer electronic equipment on the Web?

You are searching for the Holy Grail. Everyone is, but it isn't going to happen - at least not for free. Schematics are copyrighted by the equipment manufacturers who sell them as part of their service manuals or license them to organizations like Howard Sams (Sams' Photofacts) and others.

* If you reverse engineer - trace - the schematic of a TV or VCR from the unit itself - and can prove it - and then make available at your web site, that is probably legal.

* However, if you scan a service manual or Sams' Photofact and make that available at your web site, you may eventually find yourself in court.

That is my take, at least.

7.18) Taking the unit to a repair shop

As with medical problems, an accurate diagnosis can only be made with good complete information. Use your senses to their fullest. If you do decide to have the unit professionally repaired - and depending on your level of experience and confidence, this may be the wisest choice - the more complete your description of the problem the easier (and cheaper) it will be to locate the problem. Include functional behavior or lack thereof, mechanical and electronic sounds it makes, anything that is related at all to the operation of the unit. Sometimes seemingly unrelated factors can be important. For example, the fact that your officemate rearranged their desk and your monitor's image is now shaking. Don't omit anything - even what you feel is inconsequential - leave that judgement to the repair person. Also, what may have changed in your setup, did

you move the equipment recently or add a component? What about your cable connections? Did you rearrange the furniture? When was the last time you know it worked properly? What were you trying to do at the time of the failure?

To paraphrase a famous quote: 'The only stupid or useless information is that which is not provided'. However, unless you really are sure of what you are talking about, don't try to tell the repair person what you think the problem is likely to be. Don't bombard them with technobabble full of buzzwords - any competent tech will see right through that. You can be sure that if you mention that you suspect the expensive flyback is toast, it will be diagnosed as bad. Let them do their job. Listen carefully to their diagnosis. You should be able to tell if it makes sense.

7.19) Searching for information from the USENET newsgroups

There is an excellent chance that your question has come up and resulted in information being passed back and forth on sci.electronics.repair (or other appropriate newsgroup). For example, if you have had problems with a late model RCA/GE television, there have been dozens if not hundreds of postings on this subject over the last couple of years. There is no need to add to the clutter.

Dejanews is a USENET newsgroup searching facility. It has been archiving newsgroup articles since March, 1995. By going to their web site, you can invoke a search of over 15,000 newsgroups (120 GB of data!) for any set of words, names, or email addresses. Within *seconds*, they will provide a list of postings that satisfy your search criteria. Try using Dejanews at least once - you will be instantly hooked. The site URLs are:

- * <http://www.dejanews.com/> (Dejanews homepage)
- * http://www.dejanews.com/home_ps.shtml (Power search form)

While postings typically drop off of your local server in a few days or less, Dejanews maintains them *forever* so that locating an entire thread becomes a trivial exercise in identifying a search string that will narrow down the postings to those relevant to your needs.

7.20) Posting to sci.electronics.repair

This is a bit different - speculation is safer. There is enough cross-checking such that any gross errors in analysis will be uncovered. There is also generally no profit motive. If your speculation is totally bogus, you will find out quickly enough, turn various shades of red - and learn from the responses. Here are some tips:

- * Please read the on-line repair FAQs or repair guides first. Your problem may be covered. Even if an exact solution is not provided there, the additional information may allow you to ask your questions more concisely and intelligently and therefore arrive at a solution more quickly.

The FAQs can be found at:

<http://www.repairfaq.org/>

First read the README and Mirrors links to identify the best way for you to access the information from your location.

- * Put the type of device (i.e., VCR, CD player), manufacturer, and model number in the subject header as this will get the attention of the professionals. If you do not provide this info, the first reply you will receive will be to provide it. Avoid this waste of Net bandwidth. For general questions, such info may be unnecessary, but it will not hurt.
- * As with professional repairs, provide as much relevant information as possible. Ambiguity can lead to totally bogus advice. For part identification, include both the designator (e.g., R324, Q1) and type (e.g., 330K, BU407D) if available.
- * If a little circuit diagram will help, provide it in ASCII if possible. ASCII takes up almost no space and everyone (with a fixed width font) can read it. If you have a large scanned schematic, offer it via email. Large binary files are not supposed to be posted on these newsgroups. In addition, you will upset people who are forced to download a 1 MB file they have no interest in but may not know it until they see the description. Some ISPs charge for connect time and bits transferred.
- * You need to be patient. Not everyone sits at their computers all day. Some news servers may be days behind in their postings. If you truly get no replies of any kind (to the newsgroup or email) in a few days, repost your question with a note that it is a repeat. The net isn't perfect and due to finite disk space, many servers will miss postings or purge them after a day or less. Sometimes, your posting may not have made it out of the bowels of your computer system. You should be able to check this via <http://www.dejanews.com/> - see below.
- * Don't just ask for repair tips - describe what you have done so far in terms of troubleshooting approach and tests performed but don't fill screen upon screen with details. People don't want to read them. Include only the essentials if possible.
- * Don't ask for help on 25 problems in the same posting - that is taking advantage of the generosity and time of others. Dribble them out and reciprocate by replying to other people's problems as well if you can but not to just say something. If you act immature, you will end up in everyone's kill file.
- * Don't ask for help on problems that you could just as easily solve on your own by checking a databook you should have or a web site that you should know about.
- * Don't ask for an email response. First of all, it is very impolite. Sci.electronics.repair was not created for your benefit. We do this because we like to help people but at the same time do not want to feel like we are being taken advantage of or taken for granted. We are not your private consulting service. In addition, others will know when an adequate response to your query has been provided and will not need to waste their time repeating the same information. And, everyone will learn something in the process.

More importantly for you, receiving replies via email will circumvent one of the most important functions of the newsgroup - cross-checking to locate errors in responses either because the responder didn't know what they were talking about or made an error in interpretation. Perhaps, they were just being a bozo and sent an totally bogus or even dangerous response. You that was the only reply, you would never know. Yes, you will need to read the newsgroup for a few days. That will be a small sacrifice and well worth the effort.

If your news feed is indeed poor - as many are - and you are honestly afraid of missing the responses, then phrase your request for an email reply in such a way that it doesn't sound like you are totally immature and lazy.

Another alternative is to search for replies at:

This service will enable you to search for only the postings you are interested in and seems to be pretty reliable. They subscribe to a half dozen news feeds to avoid missing *your* postings!

Most people will send you a CC of their posting anyhow so avoid getting flamed for poor netiquette. However, take note below.

- * Use your true full name and email address in the 'Reply-to' field of your posting. It is unreasonable to expect us to reformat a bogus email address that you might use to avoid spams. It is quite annoying to try to help people only to receive bounced mail. While the 'delete' key works quite well in dumping the returned message, you don't get your questions answered. The regulars on the sci.electronics.xxx newsgroup hierarchy all use their real names and email addresses. Please do us a favor by being mature and do the same. Spammers lurking around these sci newsgroups get pummeled anyhow and don't survive for long :-).
- * Don't accept the first response as the definitive word. Gather a few replies and followups and then you will be able to make an evaluation of which to believe and act upon. Post a question for clarification, if needed.
- * If you do receive email responses, reply to the senders as well as posting to the newsgroup *and* indicate to the senders that you are posting a copy to the newsgroup.

It is very annoying to reply via email only to find that the same question appears a little later on the newsgroup requiring a repeat response.

In any case, once your problem has been resolved (or you have given up), it is polite to post a concise summary of the problem, suggestions, the solution or frustration, and appreciation to those who have helped you.

Chapter 8) Parts Sources

8.1) Where to go for parts

Large electronics distributors like Allied, Digikey, Mouser, Newark, and others stock tens of thousands of types of electronic components. Even Radio Shack can be used in a pinch.

However, none of these places have even the most basic service parts for consumer electronics equipment. You won't find a single rubber belt, RF modulator, posistor, or video head, nor most Japanese semiconductors within their thick catalogs.

It may be possible to go direct to the manufacturer of the equipment but expect to spend many times the true price of a part to get it from the horses mouth. In most cases, a totally identical part - with the manufacturer's logo and everything - meeting identical specifications is available elsewhere at a fraction of this cost.

(From: Don Wall (d.wall@nUNET.neu.edu)).

Unless the supplier is buying rejects or seconds (unlikely), the part is exactly the same as the 'OEM' part. This has been the case with ECG's and

NTE's for years; you pay two or three times the price to have them rebrand these parts!

Companies like Dalbani and MCM are the best thing to come along! In auto radio, I have found Pioneer, Sony, etc. IC's to be priced at anywhere from two to six times what I can buy them for from MCM.

8.2) Web parts information and ordering

Many manufacturers are now providing a great deal of *useful* information on the Web. For example, Panasonic has a web site you can enter your model number and get a parts list with list prices and part descriptions:

* <http://www.pasc.panasonic.com/> (Panasonic Parts & Service Online)

This site includes support for Panasonic, Technics, and Quasar consumer electronics. However, my quick visit only showed accessory type items (e.g., replacement original remote controls, cables, etc.). Encrypted credit card protection presumably makes it possible to order parts directly.

8.3) Mail order parts sources

The following are good sources for consumer electronics replacement parts, especially for VCRs, TVs, and other audio and video equipment. Catalogs are a must. (The first 4 I have used and have been satisfied with service and selection. The others have been recommended by others.)

- * MCM Electronics (VCR parts, Japanese semiconductors, tools, test equipment, audio, consumer electronics including microwave oven parts and electric range elements, etc.)
U.S. Voice: 1-800-543-4330.
U.S. Fax: 1-513-434-6959.
Web: <http://www.mcmelectronics.com/>
- * Dalbani (Excellent Japanese semiconductor source, VCR parts, other consumer electronics, car stereo, CATV).
U.S. Voice: 1-800-325-2264.
U.S. Fax: 1-305-594-6588.
Int. Voice: 1-305-716-0947.
Int. Fax: 1-305-716-9719.
Web: <http://www.dalbani.com/>
- * Premium Parts (Very complete VCR parts, some tools, adapter cables, other replacement parts.)
U.S. Voice: 1-800-558-9572.
U.S. Fax: 1-800-887-2727.
- * Computer Component Source (Mostly computer monitor replacement parts, also, some electronic components including semiconductors.)
U.S. Voice: 1-800-356-1227.
U.S. Fax: 1-800-926-2062.
Int. Voice: 1-516-496-8780.
Int. Fax: 1-516-496-8784.
- * Cititronix/Panson (Service parts for: Fisher, GE, Hitachi, JC Penney, JVC, Kenwood, Maganvox, Panasonic, Philco, Philips, Quasar, RCA, Sanyo, Sharp, Sony, Sylvania, Technics, Zenith)
U.S. Phone: 1-800-846-2484.
U.S. Fax: 1-800-726-0142.
- * Electro Dynamics, Inc. 135 Eileen Way, Syosset, N.Y. 11791-9022,
Phone: 1-800-426-6423.

- * **Electronix:** 313 W. Main St., Fairborn, OH 45324-5036. Phone: 937-878-1828, <http://www.electronix.com/>.
- * **Electronic Warehouse Corp.,** 1-800-221-0424.
- * **Fox International,** 1-800-321-6993.
- * **MAT Electronics:** 400 Pike Road, Huntingdon Valley, PA 19006-1610, Phone: 1-800-628-1118.
- * **Parts Express:** 340 E. First St, Dayton, OH 45429, Phone: 1-800-338-0531, Fax: 513-222-4644, Web: <http://www.parts-express.com>.
- * **RNJ Electronics:** 805 Albany Ave., P.O. Box 528, Lindenhurst, New York 11757, Phone: 1-800-645-5833.
- * **Tritronics:** 1306 Continental Drive, Abingdon, MD 21009-2334. Phone: 800-638-3328.

Also see the extensive mail order lists at:

- * http://www.repairfaq.org/REPAIR/F_Mail_Order.html
- * <http://www.mnsinc.com/bry/mega/partsupp.htm>

as well as the specific supplier lists at the end of each Repair Guide.

8.4) And, don't forget Radio Shack

Radio Shack may be the most abused chain on the sci.electronics.xxx newsgroup hierarchy but they ARE good when it is after business hours for your normal distributors, you need a resistor or capacitor, and just have to have it NOW!

In addition, Tandy, the parent company of Radio Shack is worldwide and may actually offer a USEFUL selection of components:

(From Ted Gondert (vcrepair@bbs.industry.net)).

Tandy (aka Radio Shack) has a new catalog available at your local Radio Shack; "Tech America" "Your Electronics Resource". This is special mail order catalog with many parts available from a different division of Tandy. There is no minimum order and parts are sent directly to your house. Shipping is \$4.00 for components orders only or various rates up to \$13 for orders of \$500.

Call 1-800-877-0072 between 7 a.m. to 11 p.m. M-F Central Time, 9 a.m. to 8 p.m. Saturday, 11 a.m. to 7 p.m. Sunday. Fax 1 800 813-0087. Mail: Tech America, PO BOX 1981 Fort Worth, Texas 76101-1981.

This catalog, Sept 1997 has 546 pages with capacitors, resistors, transistors, IC, coils, wires, antennas, test equipment, tools, radios, security equipment, books, etc.

The capacitors include high temperature, 105C electrolytics. The integrated circuits and transistors are mostly American type part numbers, digital, op-amps, etc. not the Japanese type used in most consumer electronics today. But should be many parts that electronics techs can use.

For example; 1000ufd 16 volt 105C electrolytic capacitor is only 39 cents. (pg 14) That's popular size in use in Panasonic SMPS. Also has MJ15024 audio output transistor for \$4.59 (pg 49) and surface mount transistors.

Radio Shack also has catalogs in stores for RSU, Radio Shack Unlimited. Those show Japanese semiconductors, special batteries, phono stylus, equipment,

etc. that your local Radio Shack can order.

(I haven't ordered anything yet but after checking my inventory and budget will probably stock up on some capacitors, etc. Get most of my parts from MCM, MAT Electronics, etc and some local distributors.)

Chapter 9) Perfecting your skills

9.1) Where to find equipment in need of repair or abuse

Now that you have read all the previous sections, perhaps some of the Repair Briefs, followed the sci.electronics.repair newsgroup for a while, built your handy widgets(tm), and loaded up on test equipment, where should you go to find broken stuff to play with and practice on? Of course, you probably have closets bulging with broken VCRs, TVs, stereos, and small appliances. You may not want to practice on these just yet.

- * One obvious source are accomodating relatives, spouses, and colleagues. However, again, you will want to hold off on this until you have some success under your belt.
- * Garage, yard, driveway, porch, etc. sales (also tag and house sales but this may be higher class more expensive junk) can be veritable bonanzas of dead appliances. With a little restraint (don't buy the first items you see until you have a feel for what the going rates are) you should be able to buy excellent dead items for next to nothing. For example, I usually don't pay more than \$5 for a dead VCR - maybe \$10 for a late model in excellent physical condition. I bought a 26" RCA Colortrak TV for \$5 and a late model 20" color TV for \$3. CD players with problems typically go for \$2 to \$7. Sometimes they will just give you the stuff so they do not have to haul it to the dump. Much of this can be repaired inexpensively once you have some experience. If you mess up some of the patients, so be it. You will have learned a great deal and sacrificed little.

Always check to see that you got all the accessories - remote controls, cables, attachments, etc. Often, they will have long since disappeared but it won't hurt to ask.

Try to find out what the symptoms were from the owner if possible. With a little knowledge, this could improve your bargaining position as well - or make you decide to try for a lesser challenge:

"Jonny stuck a peanut-butter-and-jelly sandwich in the tape slot and when his pet hamster wen't to eat the sandwich it got stuck. They have both been there for a couple of years now. I put the VCR in this plastic bag to protect it from moisture. It really is a great VCR".

or:

"Well, there was this lightning strike, the modem exploded and 6 foot flames leaped out of the monitor so I dumped a pitcher of lemonade on it to put out the fire. What is left of the PC is still melted to the floor but I figured someone could use the monitor."

I would skip those.

Another high risk would be a piece of equipment that had been worked on by someone not competent to change a light bulb:

"My VCR wouldn't play my Rambo tape so I opened it up and found this silver thing was out of line - you know, all cockeyed. So I tried to straighten it with a pair of Vise Grips(tm) but I must not have done it quite right as now all I get is snow and it makes these crunching noises. Maybe you will have more luck"

or:

"I tried to repair this amplifier but while I was making some adjustments, my screwdriver slipped and there were these HUGE sparks and bubbles appeared on several of those black things that look like cockroaches and parts flew off of those clips glued to this plate at the back. You wanted a challenge, right?"

or:

"Duh, I thought I would get cool music in my car but for some reason I cannot fathom, the jumper cables I used got really hot and my portable CD player now smells really bad and doesn't work on the normal transformer anymore. I will throw in the jumper cables for nothing."

I would pass on these as well.

In addition to melted or scorched cabinetry and the wonderful aroma of charred circuitry, look for the absence of cover screws and chisel or chainsaw marks!

- * Moving sales are similar and better in some ways as the owners are usually very motivated to move out as much junk as possible.
- * Flea markets may yield similar types of items but expect to pay more. Where do you think they obtain all their merchandise?
- * Thrift stores, Goodwill's, and similar outlets may also yield suitable candidates in some cases for free.
- * Auctions have potential as well but you better know even more about what you are bidding on, set a hard upper limit for you bids, and be prepared to spend the day.

I like to swoop in and swoop out - thus my preference for garage sales.

- * The curb, local dumpsters, and the town dump can also be sources but confirm that whatever you are taking is really up for grabs! One recommendation is to drive around a college campus at the end of the term when students are packing up and throwing away anything that they will not be taking home.

The most annoying situation is when after haggling over the price of a 'dead' VCR, you get it home with great expectations of the challenge ahead only to find that it works perfectly or your Mark-I thumb is all it takes to clean a supposedly trashed video head (but you do have to know the proper technique and incantations!) I ended up with a couple VCRs like that. A 'dead' CD player for \$5 magically cured itself on the back of my 10 speed bicycle. Often problems are simple and easily remedied resulting in quick gratification. However, there will be real dogs which could more than make up for the easy fixes (like the GE TV with the never ending string of bad solder connections). At least, if you sell the easy ones, this will help pay for your 'habit'.

- * Repair shops. They will literally have walls of beyond hope, dogs, or unclaimed equipment - TVs, VCRs, CD players, etc. It might be worth asking if you can buy some of these for a modest fee. While I am always tempted to save everything on the off chance that a part will be useful in the future, realistically, this rarely turns out to be useful and they may be happy to part with what they consider junk especially if they have more than one of the same or similar model cluttering up their back wall.

I do not know how viable an option this typically is since I have never tried it. (However, I used to trash pick mostly replaced vacuum tubes - nearly always tested good - back in those days when such things were common.) If they consider you a threat to their business, you may get the cold shoulder. If they consider you a future employee - or suspect you will make whatever you are working on worse and increase their business that way, you may be forced to take a whole pallet load of stuff off their hands :-).

Note that this could turn out to be very frustrating if by chance you end up with partially cannibalized equipment without realizing it. "This VCR does not load the tape around the video drum. Come to think of it, what happened to the video drum...?" Or, "There seems to be a big hole in the front of the TV. Now, what could possibly be missing...?"

* (From: Jerry Penner (jpenner@sentex.net)).

Make friends with several local apartment superintendants When they clean house after someone moves, they toss out all kinds of working/non-working stuff the folks left behind. Some supers make a little extra cash by fixing and reselling this stuff, some just give it the heave-ho.

One note: inspect whatever you take home. Cockroaches and other unwelcome visitors may have made a comfortable home in that old TV. I once picked up a nice toaster oven but found that I was baking more than I expected or desired and had to completely disassemble and clean it before the cockroaches stayed away permanently.

9.2) Paul's comments on the 'well equipped garage or flea market seller'

Only read the following if you are serious about this! Note: these comments apply more to the electronic flea markets or ham fests found around high tech parts of the country but can be adapted for the back woods as well.

(From: Paul Grohe) grohe@galaxy.nsc.com)).

Ah! If you are really serious about buying equipment, carry one of those little 200W 120VAC inverter bricks *with you* in your backpack, along with a cigarette socket to car battery clip adapter. Keep a small marine or gel-cell battery in your car (or with a friend who has a table).

This way, when you "roll up" on a good deal, ask the seller if you can borrow his cigarette lighter, or car battery, for a few minutes. If you can't use his car (and if you have time), run back and get your battery.

If he refuses...There's your answer!

I keep an 8-cell "AA" battery holder and an assortment of pigtail power connectors in my backpack. This way, I have an adjustable 1.5 to 12V power source to test things there on the spot (I'm planning on making a complete test box, complete with ammeter and current limiting).

I also carry a bunch of "AAA" and "C" cells in my backpack ("C" cells can be shimmed into "D" holders with a few coins between the batteries).

The same rule applies, If they won't let you test it.....etc,etc,etc.

Will they give you their business card or phone number? Make it clear you will not bother them unless absolutely necessary (secretly write down their license plate number, for "Justin Case").

Also carry a pocket DMM (This is a **must** for any flea enthusiast - NEVER buy batteries w/o testing them first!) and a small, bright flashlight (for "inspections").

Smell the equipment too! This can be a big clue as to it's condition. Does it smell like something blew up? Does it smell musty or moldy?

Another clue I have found is the physical condition of the unit. Sometimes the "cleanest" unit of the bunch is the one that failed prematurely and got stuffed on a shelf or back in the box. Whereas the "used looking" units were just taken out of service.

More importantly than "functional", is "complete".

Nuthin' worse than getting something and finding out a piece, or a board, or a module, or an expensive or rare IC is missing. Now you know it's not functional, and there may be little chance of it even becoming functional again.

I always assume "dead" until happily proven otherwise. Follow your instincts! If you have doubts, there's a reason! I always consider the scrap value of the item also. Any expensive goodies in it? The power switch may be worth more than the item!

Some of my best deals were the "I don't know if it works...Oh,..five bucks" deals.

It's a gamble...Ya' win some, ya' loose some!

Caveat Emptor!!!!

(Let duh buyer beware!)

Cheers.

9.3) And, how Paul equipped his home lab

(From: Paul Grohe) grohe@galaxy.nsc.com)).

That's me! Flea Markets/Surplus Stores/Salvation Army/Goodwill/thrift stores/Garage-yard Sales/etc...And there is **lots** of good stuff around this area!

I call it "going' Junkin'".

I arrive at about 5:30 AM, so that requires a combo krypton spotlight/fluorescent lamp flashlight (a \$3 Goodwill special :^).

I carry with me the aforementioned 8 cell battery pack, 8 "C" batteries, a bright krypton penlight, one of those all-in-one screwdriver/knife/pliers/scissors/bottle opener contraptions ("fishermans friend"?) and a small pocket DMM. All about 5-7 pounds total. I carry it all in a backpack that I wear "backwards" on my chest (for easy access). During the "lull" (around 9 AM), I go back and "load transfer" to the car.

I got it down to a science!! ;^)

After some lucky "scores", and a few **hundred** hours of troubleshooting, I have a **very** well stocked home lab... :^)

My home lab is graced with a Tek 576 Curve tracer (bad Xfmr), HP 5345 Freq

cntr (bad NPN tranny), HP3456 DMM (bad ROM), Radiometer 106 RF Generator (stuck keys), Genrad 1688 Digital RCL meter (another bad ROM) and a "few" other assorted goodies...

The Tek 576 is my favorite. This unit was the one of the bunch that failed early and was shelved. It was dusty, dirty, full of spider webs, and missing one little knob, but in otherwise perfect shape. I got it for \$200. Guys were offering me \$750 for it "as-is" on the way back to the car! To top it off, two tables down from where I got the 576, someone was selling a *complete* set of the transistor/diode plug-in fixtures. Score #2!

It was a good day..... I used up all of my allocated "luck" for that year. :^)

The 576's collector supply transformers primary was dead-shortened. Eventually I was lead to Dean Kidd, who sold me a *brand new* one for \$75! Tek even took the bad transformer back for failure analysis!

The HP frequency counter was the longest fix (~2 months). It's all jelly-bean TTL logic (some ECL), but no "brains" at all! Board swapping with a friends unit and some "shotgunning" brought it to back life. The eventual root failure was a single NPN transistor, in a buffer between two stages of the main 500MHz counters, whose beta had dropped significantly. I stuck a 2N2222 in there to check it out, and "there" it remains to this day!

"If it's no longer broke, Quit fixin' it!" - Paul Grohe ;^)

The Genrad was the "hair-puller" (really made me begin to doubt my troubleshooting skills!). It would continually fail it's self check at the same step. The failure code indicated a certain section of the analog section, which I *knew* was okay. There is not much to the analog section anyways! It is mostly jelly-bean, off-the-shelf 74C series digital logic sitting around a 6502 uProc. After checking *every* analog part (most out-of-circuit), and swapping all of the digital chips, I concluded it *must* be the ROM. It was the only part left that had not been replaced! I posted for a "brain donor" and got a reply. He had two dead units and offered to send me the ROM's to compare and read. I took him up on his offer and copied the ROM, and then transferred it to an EPROM. Voila! The f#@!#g thing worked! I chased my tail for weeks! It turns out that a few bits in the ROM were corrupted, and the error was subtle enough to cause it to just "trip-up" at that phase of the self-test, even though the hardware was fine. Arrrrgghh!! I sent him his ROM's back, with a little "thank-you", and eventually helped him revive his two units. This was one of those "fun" repairs.

Everything else I have was dead, dying or crippled (er, "functionally challenged"). I even had to repair my 475A O'scope before I could use it! (It's a "P-I-T-A" to troubleshoot a scope w/o a scope!)

9.4) Too bad about the good old days

(From: Mike Diack (moby@kcbbs.gen.nz)).

In the days before 'Weirdstuff Warehouse' stopped being weird and simply became boring, a lot of the junkus electronicus they sold bore a sticker stating:

This equipment is guaranteed not to work - should you find that it does, we will be happy to exchange it for something that doesn't.

Treat fleas the same.

(From: Paul Grohe (grohe@galaxy.nsc.com)).

Yep! I bought a lot of "goodies" with that little orange and black sticker!! I resisted the temptation to take it back if it worked. If it did work, I broke it, then fixed it, so then I would not feel so "guilty". ;^)

9.5) Harrie's notes on repair

(From: Harrie Gulikers (hgu@oce.nl)).

Just want to share my experience on repairing electronic devices in general. After many (most successful) repairments I've concluded the following:

- * If I need a schematic, then I'm really desperate, probably have spent too many hours by now on the device.
- * Most of the problems were due to bad wiring between components. You must interpret this very general: bad solderdots (most common problem), bad contacts in connector, etc.
- * 10 years ago and earlier, warm components were soldered with with straight leads to the solder-dots. After a few years these solder-dots come loose, or make bad contact because the leads vary in length due to temperature variations. Mostly you can see this with the bare eye. Just re-solder all big (warm) components, like transistors attached to heatsinks, big capacitors, coils etc. This works also preventive for future problems. Also, try to bend straight leads.

These bad contacts were the cause for, say 75% of all devices I have repaired for the past 16 years. If (and IF) a component was damaged, it was because of bad contacts.

Take this advice in mind and I hope you can profit from it.
Repair shops probably will throw a stone towards my head ;-)

9.6) Roger's comments on troubleshooting

(From: Roger Pariseau (grinder@west.net)).

The closest I ever came to bench tekking was when I would service electronic organs at a dealer's warehouse. If I spent all day there I'd normally fix upwards of 20 instruments and "check out" several others. Normally I just "ran traps" at churches, auditoriums, schools and homes where I got to five or six instruments a day.

I dealt with intermittents via a little rubber mallet and a can of cold spray!

And, I learned a couple of things:

1. 'Shotgun' a bad circuit.
2. If an amp's outputs are blown, check/replace the speakers also
3. Digital circuits are **not** logical!
4. Never hurry.
5. Check **all** supply voltages first.

6. Check all signal generation and their paths (some organs derived their rhythm section's clock from a generated note - there are similar circuits in TVs).

7. Burn-in your work - it can go out the next day.

It was a great little business until the mid '80s when the Casios and the Yamahas became popular. Now I mostly repair computers with the occasional piece of HiFi gear hitting my bench. Like that damned Sony 100-disc CD player that I can't find parts values for!

Written by Samuel M. Goldwasser.  / [\[mailto\]](#). The most recent version is available on the WWW server <http://www.repairfaq.org/> [[Copyright](#)] [[Disclaimer](#)]